

# Gewindeschneidfutter

## *Tap Holders*



**Technische Informationen**

- Alle Gewindeschneidfutter werden incl. Standard-Mutter geliefert
- Gewindeschneidfutter mit "AK" werden incl. abgedichteter Mutter (System Rego-fix) geliefert.
- Abkürzungen bei den Halter-Bezeichnungen siehe auch Technische Informationen S. 4 + 5
- Siehe auch Katalog:  
"Werkstück und Werkzeugspannung":  
Gewindebohrspannzangen und Spannzangen mit Längenausgleich

**Technical Information**

- *All tap holders will be supplied with clamping nut (standard)*
- *Tap holders with "AK" will be supplied with sealed nut type Rego-fix*
- *Abbreviations for holders see technical information page 4 + 5*
- *See also catalog:  
"Workpiece and Tool Clamping":  
Tapping collets and  
tapping collets with length adjustment*

**Gewindeschneidfutter ER08M / ER11M**  
 extrem kleine Baumaße, präzise Führung

**Tap Holders ER08M / ER11M**  
 Extremely Small Dimensions, Precisely Guided

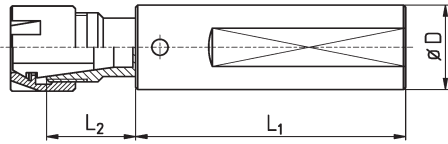

Bestell-Nr. order-no.	Zange collet	D	L <sub>1</sub>	L <sub>2</sub>	Auszug pullout	Bereich range	Mutter nut
GFM081450WD	ER08	14	50	10	7	M1 - M6	ER08M
GFM085840WD	ER08	5/8"	40	10	7	M1 - M6	ER08M
GFM085850WD	ER08	5/8"	50	10	7	M1 - M6	ER08M
GFM081650WD	ER08	16	50	10	7	M1 - M6	ER08M
GFM081945BU	ER08	3/4"	45	10	7	M1 - M6	ER08M
GFM111450WD	ER11	14	50	18	7	M1 - M8	ER11M
GFM115840WD	ER11	5/8"	40	18	7	M1 - M8	ER11M
GFM115850WD	ER11	5/8"	50	18	7	M1 - M8	ER11M
GFM111650WD	ER11	16	50	18	7	M1 - M8	ER11M
GFM111945BU	ER11	3/4"	45	18	7	M1 - M8	ER11M



ER08M = M10 x 0,75



ER11M = M13 x 0,75

**Gewindeschneidfutter ER11 / ER11M**  
 schlanke Bauform, präzise Führung

**Tap Holders ER11 / ER11M**  
 Slim Type, Precisely Guided

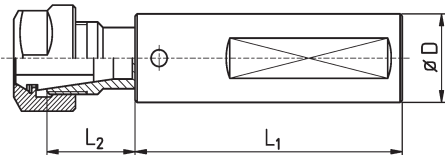
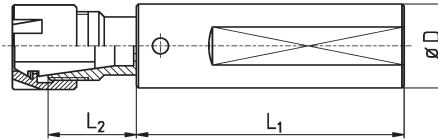
**Beispiel - example:**
**Halter GFM mit durchgehender Spannfläche WD**  
**Holder GFM with clamping flat throughout WD**

**Beispiel - example:**
**Halter GFU mit abgesetzter Spannfläche FL**  
**Holder GFU with enclosed clamping flat FL**

UM/ER11 = M14 x 0,75



ER11M = M13 x 0,75

Bestell-Nr. order-no.	D	L <sub>1</sub>	L <sub>2</sub>	Mutter nut
GFU111645BU	16	45	9	UM/ER11
GFU111838	18	38	9	UM/ER11
GFU111880	18	80	9	UM/ER11
GFU1118130BU	18	130	9	UM/ER11
GFU1118250BU	18	250	9	UM/ER11
GFU111945BU	3/4"	45	9	UM/ER11
GFU111950	3/4"	50	9	UM/ER11
GFU111950FL	3/4"	50	9	UM/ER11
GFU111960FL	3/4"	60	9	UM/ER11
GFU111970	3/4"	70	9	UM/ER11
GFU111970FL	3/4"	70	9	UM/ER11
GFU111970WD	3/4"	70	9	UM/ER11
GFU1119120FL	3/4"	120	9	UM/ER11
GFU112050WD	20	50	9	UM/ER11
GFU112050BU	20	50	10	UM/ER11
GFU112060FL	20	60	10	UM/ER11
GFU112070	20	70	9	UM/ER11
GFU112070WD	20	70	9	UM/ER11
GFU112070WDBU	20	70	9	UM/ER11
GFU1120120WD	20	120	9	UM/ER11
GFU1120150BU	20	150	9	UM/ER11
GFU112225SRR	22	25	9	UM/ER11
GFU112250FL	22	50	9	UM/ER11
GFU112270	22	70	9	UM/ER11
GFU112270WD	22	70	9	UM/ER11
GFU1122100	22	100	9	UM/ER11
GFU1122100WD	22	100	9	UM/ER11
GFU112570	25	70	9	UM/ER11
GFU112570FL	25	70	9	UM/ER11
GFU112570FLBU	25	70	9	UM/ER11
GFU1125140WDBU	25	140	9	UM/ER11
GFU112650	1"	50	9	UM/ER11
GFU112650WD	1"	50	9	UM/ER11
GFU112670	1"	70	9	UM/ER11
GFU112670WD	1"	70	9	UM/ER11
GFU112670FLBU	1"	70	9	UM/ER11
GFU112880FL	28	80	9	UM/ER11

Bestell-Nr. order-no.	D	L <sub>1</sub>	L <sub>2</sub>	Mutter nut
GFM111645BU	16	45	10	ER11M
GFM111838	18	38	9	ER11M
GFM111880	18	80	10	ER11M
GFM1118130BU	18	130	10	ER11M
GFM1118250BU	18	250	10	ER11M
GFM111945BU	3/4"	45	10	ER11M
GFM111950	3/4"	50	10	ER11M
GFM111950FL	3/4"	50	10	ER11M
GFM111960FL	3/4"	60	10	ER11M
GFM111970	3/4"	70	10	ER11M
GFM111970FL	3/4"	70	10	ER11M
GFM111970WD	3/4"	70	10	ER11M
GFM1119120FL	3/4"	120	10	ER11M
GFM112050WD	20	50	10	ER11M
GFM112050BU	20	50	10	ER11M
GFM112060FL	20	60	10	ER11M
GFM112070	20	70	10	ER11M
GFM112070WD	20	70	10	ER11M
GFM112070WDBU	20	70	10	ER11M
GFM1120120WD	20	120	10	ER11M
GFM1120150BU	20	150	10	ER11M
GFM112225SRR	22	25	10	ER11M
GFM112250FL	22	50	10	ER11M
GFM112270	22	70	10	ER11M
GFM112270WD	22	70	10	ER11M
GFM1122100	22	100	10	ER11M
GFM1122100WD	22	100	10	ER11M
GFM112570	25	70	9	ER11M
GFM112570FL	25	70	9	ER11M
GFM112570FLBU	25	70	9	ER11M
GFM1125140WDBU	25	140	9	ER11M
GFM112650	1"	50	9	ER11M
GFM112650WD	1"	50	9	ER11M
GFM112670	1"	70	9	ER11M
GFM112670WD	1"	70	9	ER11M
GFM112670FLBU	1"	70	9	ER11M
GFM112880FL	28	80	10	ER11M

**Gewindeschneidfutter ER16 /ER16M /ER20M**  
schlanke Bauform, präzise Führung

**Tap Holders ER16 /ER16M /ER20M**  
Slim Type, Precisely Guided

Beispiel - example:  
Halter GFM mit durchgehender Spannfläche WD  
Holder GFM with clamping flat throughout WD

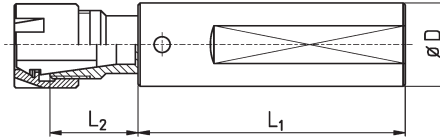
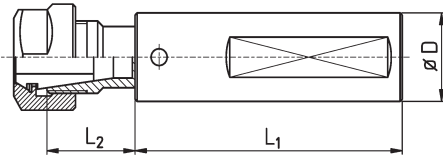

Beispiel - example:  
Halter GFU mit abgesetzter Spannfläche FL  
Holder GFU with enclosed clamping flat FL

Bestell-Nr. order-no.	D	L <sub>1</sub>	L <sub>2</sub>	Mutter nut
GFU161645BU	16	45	19	UM/ER16
GFU161838	18	38	19	UM/ER16
GFU161880	18	80	19	UM/ER16
GFU1618130BU	18	130	19	UM/ER16
GFU1618250BU	18	250	19	UM/ER16
GFU161945BU	3/4"	45	19	UM/ER16
GFU161950	3/4"	50	19	UM/ER16
GFU161950FL	3/4"	50	19	UM/ER16
GFU161960FL	3/4"	60	19	UM/ER16
GFU161970	3/4"	70	19	UM/ER16
GFU161970FL	3/4"	70	19	UM/ER16
GFU161970WD	3/4"	70	19	UM/ER16
GFU1619120FL	3/4"	120	19	UM/ER16
GFU162050WD	20	50	19	UM/ER16
GFU162050BU	20	50	19	UM/ER16
GFU162060FL	20	60	19	UM/ER16
GFU162070	20	70	19	UM/ER16
GFU162070WD	20	70	19	UM/ER16
GFU162070WDBU	20	70	19	UM/ER16
GFU1620120WD	20	120	19	UM/ER16
GFU1620150BU	20	150	19	UM/ER16
GFU162225SRR	22	25	19	UM/ER16
GFU162250FL	22	50	19	UM/ER16
GFU162270	22	70	19	UM/ER16
GFU162270WD	22	70	19	UM/ER16
GFU1622100	22	100	19	UM/ER16
GFU1622100WD	22	100	19	UM/ER16
GFU162570	25	70	20	UM/ER16
GFU162570FL	25	70	20	UM/ER16
GFU162570FLBU	25	70	20	UM/ER16
GFU1625140WDBU	25	140	20	UM/ER16
GFU162650	1"	50	20	UM/ER16
GFU162650WD	1"	50	20	UM/ER16
GFU162670	1"	70	20	UM/ER16
GFU162670WD	1"	70	20	UM/ER16
GFU162670FLBU	1"	70	20	UM/ER16
GFU162880FL	28	80	19	UM/ER16
GFU16V20	20	40	41	UM/ER16

Bestell-Nr. order-no.	D	L <sub>1</sub>	L <sub>2</sub>	Mutter nut
GFM161645BU	16	45	19	ER16M
GFM161838	18	38	19	ER16M
GFM161880	18	80	19	ER16M
GFM1618130BU	18	130	19	ER16M
GFM1618250BU	18	250	19	ER16M
GFM161945BU	3/4"	45	19	ER16M
GFM161950	3/4"	50	19	ER16M
GFM161950FL	3/4"	50	19	ER16M
GFM161960FL	3/4"	60	19	ER16M
GFM161970	3/4"	70	19	ER16M
GFM161970FL	3/4"	70	19	ER16M
GFM161970WD	3/4"	70	19	ER16M
GFM1619120FL	3/4"	120	19	ER16M
GFM162050WD	20	50	19	ER16M
GFM162050BU	20	50	19	ER16M
GFM162060FL	20	60	19	ER16M
GFM162070	20	70	19	ER16M
GFM162070WD	20	70	19	ER16M
GFM162070WDBU	20	70	19	ER16M
GFM1620120WD	20	120	19	ER16M
GFM1620150BU	20	150	19	ER16M
GFM162225SRR	22	25	19	ER16M
GFM162250FL	22	50	19	ER16M
GFM162270	22	70	19	ER16M
GFM162270WD	22	70	19	ER16M
GFM1622100	22	100	19	ER16M
GFM1622100WD	22	100	19	ER16M
GFM162570	25	70	20	ER16M
GFM162570FL	25	70	20	ER16M
GFM162570FLBU	25	70	20	ER16M
GFM1625140WDBU	25	140	20	ER16M
GFM162650	1"	50	20	ER16M
GFM162650WD	1"	50	20	ER16M
GFM162670	1"	70	20	ER16M
GFM162670WD	1"	70	20	ER16M
GFM162670FLBU	1"	70	20	ER16M
GFM162880FL	28	80	19	ER16M
GFM16V20	20	40	41	ER16M

Bestell-Nr. order-no.	Zange collet	D	L <sub>1</sub>	L <sub>2</sub>	Bereich range	Mutter nut	Gewinde thread	Schlüssel spanner
GFM202670FL	ER20	1"	70	17	M1 - M10	ER20M	M24x1	E20M

**Gewindeschneidfutter ER16M**  
 schlanke Bauform, präzise Führung  
 mit axialer Kühlmittelzufuhr

**Tap Holders ER16M**  
 Slim Type, Precisely Guided  
 with Axial Coolant



ER16M = M19 x 1

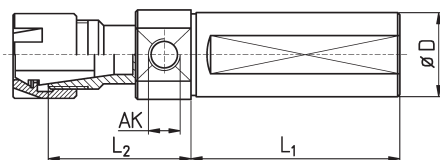

Bestell-Nr. order-no.	Bereich range	Auszug pullout	D	L <sub>1</sub>	L <sub>2</sub>	AK	Zange collet	Mutter nut
GFM161645AK1WD	M1 - M8	7 mm	16	45	36	G1/8"	ER16	ER16M
GFM161950AK1WD	M1 - M8	7 mm	3/4"	50	36	G1/8"	ER16	ER16M
GFM162050AK1WD	M1 - M8	7 mm	20	50	36	G1/8"	ER16	ER16M
GFM162070AK1WD	M1 - M8	7 mm	20	70	36	G1/8"	ER16	ER16M
GFM162270AK1WD	M1 - M8	7 mm	22	70	36	G1/8"	ER16	ER16M
GFM162570AK1WD	M1 - M8	7 mm	25	70	36	G1/8"	ER16	ER16M
GFM162670AK1WD	M1 - M8	7 mm	1"	70	36	G1/8"	ER16	ER16M

**Gewindeschneidfutter ER - Standardgewinde**  
 extrem kleine Baumaße, Sechskantführung

**Tap Holders ER - standard thread**  
 Extremely Small Dimensions, Hexagon Guidance

Ausführungen:  
 Versions:

WD: Spannfläche durchgehend  
 WD: Clamping flat throughout

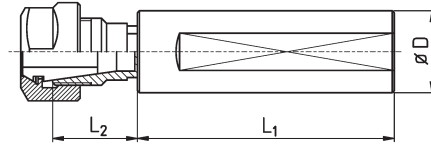

FL: Spannfläche abgesetzt  
 FL: Enclosed clamping flat

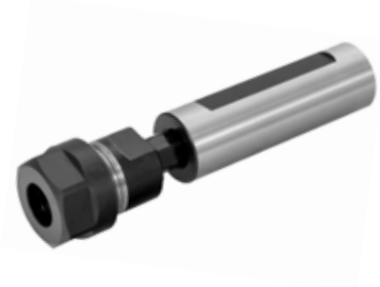
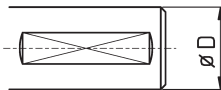

Halter Holder		
Bestell-Nr. order-no.	D	L <sub>1</sub>
GSU**1438	14	38
GSU**1450	14	50
GSU**1635	16	35
GSU**1670	16	70
GSU**16120	16	120
GSU**18125WDBU	18	125
GSU**1938	3/4"	38
GSU**1938FL	3/4"	38
GSU**1950	3/4"	50
GSU**1950FL	3/4"	50
GSU**1970FL	3/4"	70
GSU**19120	3/4"	120
GSU**19120FL	3/4"	120
GSU**2038FL	20	38
GSU**2050FL	20	50
GSU**2070FL	20	70
GSU**20120WD	20	120
GSU**2238FL	22	38
GSU**2250FL	22	50
GSU**2270FL	22	70
GSU**22120FL	22	120
GSU**2538FL	25	38
GSU**2550FL	25	50
GSU**2570FL	25	70
GSU**2580FL	25	80
GSU**2638FL	1"	38
GSU**2650	1"	50
GSU**2650FL	1"	50
GSU**2670FL	1"	70
GSU**2675	1"	75
GSU**2675FL	1"	75
GSU**2680FL	1"	80
GSU**26125FL	1"	125

Zange ER11 collet ER11		
L <sub>2</sub>	Bereich range	Mutter nut
10	M1 - M6	UM/ER11



Zange ER16 collet ER16		
L <sub>2</sub>	Bereich range	Mutter nut
27	M1 - M8	UM/ER16



Zange ER20 collet ER20		
L <sub>2</sub>	Bereich range	Mutter nut
32	M2 - M16	UM/ER20



Bestell-Nr.: \*\* Wird ersetzt durch die Nenngröße der gewünschten Zangenhalterung (11 / 16 od. 20)  
 order-no.: \*\* To be replaced by the collet-no. of the collet holder (11 / 16 or 20)

**Gewindeschneidfutter ER - Minigewinde**  
extrem kleine Baumaße, Sechskantführung

**Tap Holders ER - mini thread**  
Extremely Small Dimensions, Hexagon Guidance

Ausführungen:  
Versions:

WD: Spannfläche durchgehend  
WD: Clamping flat throughout

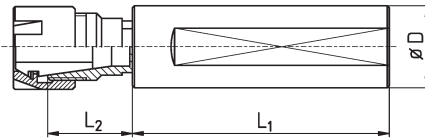

FL: Spannfläche abgesetzt  
FL: Enclosed clamping flat

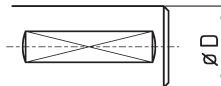

Halter Holder		
Bestell-Nr. order-no.	D	L <sub>1</sub>
GSM**1438	14	38
GSM**1450	14	50
GSM**1635	16	35
GSM**1670	16	70
GSM**16120	16	120
GSM**18125WDBU	18	125
GSM**1938	3/4"	38
GSM**1938FL	3/4"	38
GSM**1950	3/4"	50
GSM**1950FL	3/4"	50
GSM**1970FL	3/4"	70
GSM**19120	3/4"	120
GSM**19120FL	3/4"	120
GSM**2038FL	20	38
GSM**2050FL	20	50
GSM**2070FL	20	70
GSM**20120WD	20	120
GSM**2238FL	22	38
GSM**2250FL	22	50
GSM**2270FL	22	70
GSM**22120FL	22	120
GSM**2538FL	25	38
GSM**2550FL	25	50
GSM**2570FL	25	70
GSM**2580FL	25	80
GSM**2638FL	1"	38
GSM**2650	1"	50
GSM**2650FL	1"	50
GSM**2670FL	1"	70
GSM**2675	1"	75
GSM**2675FL	1"	75
GSM**2680FL	1"	80
GSM**26125FL	1"	125

Zange ER11 collet ER11		
L <sub>2</sub>	Bereich range	Mutter nut
10	M1 - M6	ER11M



ER11M = M13 x 0,75

Zange ER16 collet ER16		
L <sub>2</sub>	Bereich range	Mutter nut
27	M1 - M8	ER16M



ER16M = M19 x 1

Zange ER20 collet ER20		
L <sub>2</sub>	Bereich range	Mutter nut
32	M2 - M16	ER20M



ER20M = M24 x 1

Bestell-Nr.: \*\* wird ersetzt durch die Nenngröße der gewünschten Zangenhalterung (11 / 16 od. 20)  
order-no.: \*\* To be replaced by the collet-no. of the collet holder (11 / 16 or. 20)



**Gewindeschneidfutter ER11 / ER11M  
ER16 / ER16M für STAR**

**Tap Holders ER11 / ER11M  
ER16 / ER16M for STAR**

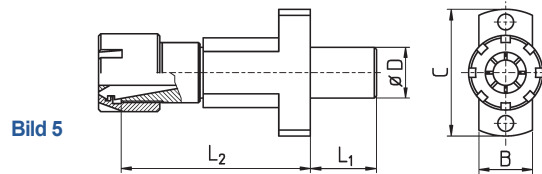
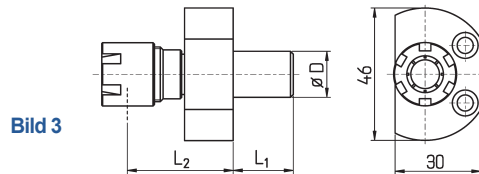
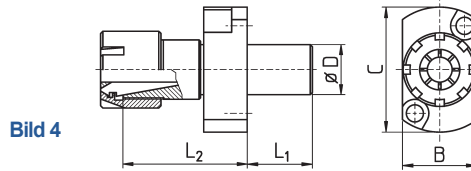
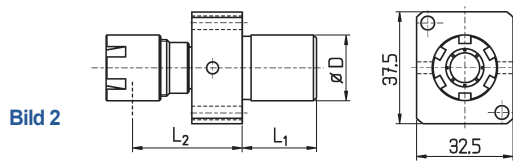
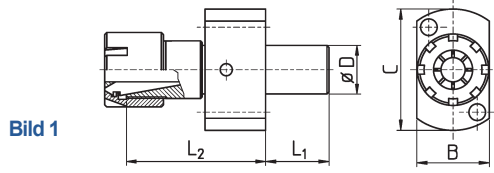

Bestell-Nr. order-no.	D	L <sub>1</sub>	L <sub>2</sub>	B	C	Bild picture	Mutter nut	Maschinen-Typ machine type
GFM111610SRJ	16	10	43	17	40	5	ER11M	SR10J (Pos T21 + T23)
GFU111610SRJ	16	10	43	17	40	5	UM/ER11	
GFM161610SRJ	16	10	53	17	40	5	ER16M	
GFU161610SRJ	16	10	53	17	40	5	UM/ER16	
GSM111621SR	16	21	24,5	24	40	4	ER11M	SR16 ; SR20
GSU111621SR	16	21	24,5	24	40	4	UM/ER11	
GSM161621SR	16	21	42	24	40	4	ER16M	
GSU161621SR	16	21	42	24	40	4	UM/ER16	
GSM161621RNC	16	21	45	30	46	3	ER16M	SR16
GSU161621RNC	16	21	45	30	46	3	UM/ER16	
GFM112225SRR	22	25	20,5	28	49	1	ER11M	SR10J (Pos T22+ T24) ; SB12 / 20R ; SB16 / 20 ; SR20J / JN ; SR32J / JN ; SR20 R / II / III ; SV20R ; SW12RII ; ECAS12/20 SR20RIV (Pos T21 - T24 verbaut / overlaps T25 - T28)
GFU112225SRR	22	25	29,5	28	49	1	UM/ER11	
GFM162225SRR	22	25	29,5	28	49	1	ER16M	
GFU162225SRR	22	25	29,5	28	49	1	UM/ER16	
GSM162225SRR	22	25	29,5	28	49	1	ER16M	
GSU162225SRR	22	25	29,5	28	49	1	UM/ER16	
GFM112225SW	22	25	27			2	ER11M	SW20 ; SW12RII ; SV20R ; SR20RIV ; SB12 / 20R ; SR38
GFU112225SW	22	25	36	32,5	37,5	2	UM/ER11	
GFM162225SW	22	25	36			2	ER16M	
GFU162225SW	22	25	36	32,5	37,5	2	UM/ER16	
GFM112225SR	22	25	19	38	48	1	ER11M	SR32 ; SR32J
GFU112225SR	22	25	28	38	48	1	UM/ER11	
GFM162225SR	22	25	28	38	48	1	ER16M	
GFU162225SR	22	25	28	38	48	1	UM/ER16	



ER11M = M13 x 0,75



ER16M = M19 x 1



UM/ER11 = M14 x 0,75



UM/ER16 = M22 x 1,5

### Gewindeschneidfutter ER20M / ER25M kugelgelagert

### Tap Holders ER20M / ER25M Ball Bearing Guided

Ausführungen:  
Versions:

WD: Spannfläche durchgehend  
WD: Clamping flat throughout

FL: Spannfläche abgesetzt  
FL: Enclosed clamping flat

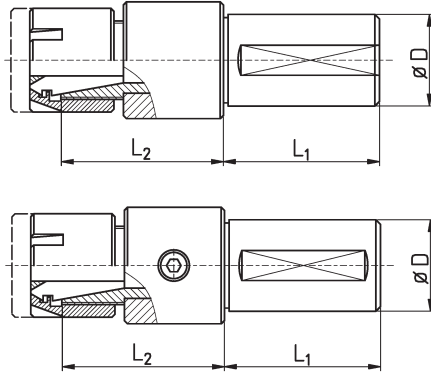

Bestell-Nr. order-no.	Zange collet	D	L <sub>1</sub>	L <sub>2</sub>
GKM201650FL DZ	ER20	16	50	47
GKM201650FL	ER20	16	50	47
GKM201946	ER20	3/4"	46	47
GKM2019100	ER20	3/4"	100	47
GKM202032FL	ER20	20	32	47
GKM202050	ER20	20	50	47
GKM202050FL DZ	ER20	20	50	47
GKM202050FL	ER20	20	50	47
GKM2020100FL	ER20	20	100	47
GKM202275FL	ER20	22	75	47
GKM202550FL	ER20	25	50	47
GKM202555FL DZ	ER20	25	55	47
GKM202555 DZ	ER20	25	55	47
GKM202575FL	ER20	25	75	47
GKM2025100	ER20	25	100	47
GKM2025100WD DZ	ER20	25	100	47
GKM2025100WD	ER20	25	100	47
GKM2025120WD	ER20	25	120	47
GKM202646 DZ	ER20	1"	46	47
GKM202650	ER20	1"	50	47
GKM202675	ER20	1"	75	47
GKM202675FL	ER20	1"	75	47
GKM2026100	ER20	1"	100	47
GKM2026100WD	ER20	1"	100	47
GKM203150	ER20	1 1/4"	50	47
GKM203155	ER20	1 1/4"	55	47
GKM203255FL DZ	ER20	32	55	47
GKM203255 DZ	ER20	32	55	47
GKM203260WD	ER20	32	60	47
GKM204060WD DZ	ER20	40	60	47
GKM204060WD	ER20	40	60	47
GKM204085WD	ER20	40	85	47

Bestell-Nr. order-no.	Zange collet	D	L <sub>1</sub>	L <sub>2</sub>
GKM251650FL DZ	ER25	16	50	45
GKM251650FL	ER25	16	50	45
GKM251946	ER25	3/4"	46	45
GKM2519100	ER25	3/4"	100	45
GKM252032FL	ER25	20	32	45
GKM252050	ER25	20	50	45
GKM252050FL DZ	ER25	20	50	45
GKM252050FL	ER25	20	50	45
GKM2520100FL	ER25	20	100	45
GKM252275FL	ER25	22	75	45
GKM252550FL	ER25	25	50	45
GKM252555FL DZ	ER25	25	55	45
GKM252555 DZ	ER25	25	55	45
GKM252575FL	ER25	25	75	45
GKM2525100	ER25	25	100	45
GKM2525100WD DZ	ER25	25	100	45
GKM2525100WD	ER25	25	100	45
GKM2525120WD	ER25	25	120	45
GKM252646 DZ	ER25	1"	46	45
GKM252650	ER25	1"	50	45
GKM252675	ER25	1"	75	45
GKM252675FL	ER25	1"	75	45
GKM2526100	ER25	1"	100	45
GKM2526100WD	ER25	1"	100	45
GKM253150	ER25	1 1/4"	50	45
GKM253155	ER25	1 1/4"	55	45
GKM253255FL DZ	ER25	32	55	45
GKM253255 DZ	ER25	32	55	45
GKM253260WD	ER25	32	60	45
GKM254060WD DZ	ER25	40	60	45
GKM254060WD	ER25	40	60	45
GKM254085WD	ER25	40	85	45



ER20M = M24 x 1



ER25M = M30 x 1

#### Gewindeschneidfutter ER20 / ER25 kugelgelagert

#### Tap Holders ER20 / ER25 Ball Bearing Guided

Ausführungen:  
Versions:

WD: Spannfläche durchgehend  
WD: Clamping flat throughout

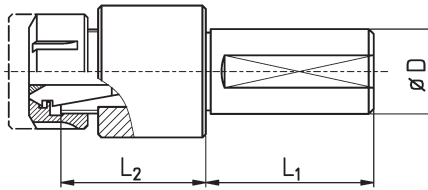

FL: Spannfläche abgesetzt  
FL: Enclosed clamping flat

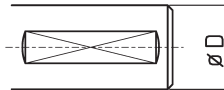

Bestell-Nr. order-no.	Zange collet	D	L <sub>1</sub>	L <sub>2</sub>
GKU201650FL DZ	ER20	16	50	47
GKU201650FL	ER20	16	50	47
GKU201946	ER20	3/4"	46	47
GKU2019100	ER20	3/4"	100	47
GKU202032FL	ER20	20	32	47
GKU202050	ER20	20	50	47
GKU202050FL DZ	ER20	20	50	47
GKU202050FL	ER20	20	50	47
GKU2020100FL	ER20	20	100	47
GKU202275FL	ER20	22	75	47
GKU202550FL	ER20	25	50	47
GKU202555FL DZ	ER20	25	55	47
GKU202555 DZ	ER20	25	55	47
GKU202575FL	ER20	25	75	47
GKU2025100	ER20	25	100	47
GKU2025100WD DZ	ER20	25	100	47
GKU2025100WD	ER20	25	100	47
GKU2025120WD	ER20	25	120	47
GKU202646 DZ	ER20	1"	46	47
GKU202650	ER20	1"	50	47
GKU202675	ER20	1"	75	47
GKU202675FL	ER20	1"	75	47
GKU2026100	ER20	1"	100	47
GKU2026100WD	ER20	1"	100	47
GKU203150	ER20	1 1/4"	50	47
GKU203155	ER20	1 1/4"	55	47
GKU203255FL DZ	ER20	32	55	47
GKU203255 DZ	ER20	32	55	47
GKU203260WD	ER20	32	60	47
GKU204060WD DZ	ER20	40	60	47
GKU204060WD	ER20	40	60	47
GKU204085WD	ER20	40	85	47

Bestell-Nr. order-no.	Zange collet	D	L <sub>1</sub>	L <sub>2</sub>
GKU251650FL DZ	ER25	16	50	45
GKU251650FL	ER25	16	50	45
GKU251946	ER25	3/4"	46	45
GKU2519100	ER25	3/4"	100	45
GKU252032FL	ER25	20	32	45
GKU252050	ER25	20	50	45
GKU252050FL DZ	ER25	20	50	45
GKU252050FL	ER25	20	50	45
GKU2520100FL	ER25	20	100	45
GKU252275FL	ER25	22	75	45
GKU252550FL	ER25	25	50	45
GKU252555FL DZ	ER25	25	55	45
GKU252555 DZ	ER25	25	55	45
GKU252575FL	ER25	25	75	45
GKU2525100	ER25	25	100	45
GKU2525100WD DZ	ER25	25	100	45
GKU2525100WD	ER25	25	100	45
GKU2525120WD	ER25	25	120	45
GKU252646 DZ	ER25	1"	46	45
GKU252650	ER25	1"	50	45
GKU252675	ER25	1"	75	45
GKU252675FL	ER25	1"	75	45
GKU2526100	ER25	1"	100	45
GKU2526100WD	ER25	1"	100	45
GKU253150	ER25	1 1/4"	50	45
GKU253155	ER25	1 1/4"	55	45
GKU253255FL DZ	ER25	32	55	45
GKU253255 DZ	ER25	32	55	45
GKU253260WD	ER25	32	60	45
GKU254060WD DZ	ER25	40	60	45
GKU254060WD	ER25	40	60	45
GKU254085WD	ER25	40	85	45



UM/ER20 = M25 x 1,5



UM/ER25 = M32 x 1,5

## Gewindeschneidfutter ER32 kugellagert

Tap Holders ER32  
Ball Bearing Guided

### Ausführungen:

Versions:

WD: Spannfläche durchgehend

WD: Clamping flat troughout

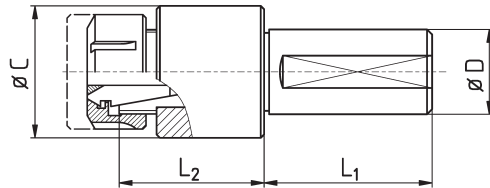

Halter mit äußerer Kühlmittelzufuhr AK  
und abgesetzter Spannfläche FL

Holder with inner coolant AK  
and enclosed clamping flat FL

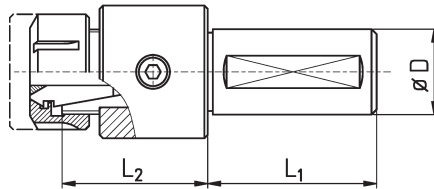

Bestell-Nr. order-no.	Zange collet	D	L <sub>1</sub>	L <sub>2</sub>	C	AK	Bereich range	Mutter Nut
GKU321950AK	ER32	3/4"	50	54	50	AK	M6 - M28	UM/ER32
GKU322050	ER32	20	50	57	50	--	M6 - M28	UM/ER32
GKU322050AKFL	ER32	20	50	57	50	AK	M6 - M28	UM/ER32
GKU322050DZ	ER32	20	50	54	50	--	M6 - M28	UM/ER32
GKU322050FLDZ	ER32	20	50	54	50	--	M6 - M28	UM/ER32
GKU322550AKFL	ER32	25	50	57	50	AK	M6 - M28	UM/ER32
GKU322555DZ	ER32	25	55	54	50	--	M6 - M28	UM/ER32
GKU322650	ER32	1"	50	54	50	--	M6 - M28	UM/ER32
GKU322650AK	ER32	1"	50	54	50	AK	M6 - M28	UM/ER32
GKU323150	ER32	1 1/4"	50	54	50	--	M6 - M28	UM/ER32
GKU323158DZ	ER32	1 1/4"	58	54	50	--	M6 - M28	UM/ER32
GKU323250AKFL	ER32	32	50	57	50	AK	M6 - M28	UM/ER32
GKU323260DZ	ER32	32	60	54	50	--	M6 - M28	UM/ER32
GKU323260FLDZ	ER32	32	60	54	50	-	M6 - M28	UM/ER32
GKU324070AKFL	ER32	40	70	57	50	AK	M6 - M28	UM/ER32
GKU324070AKWDDZ	ER32	40	70	54	50	AK	M6 - M28	UM/ER32
GKU3250100AKFL	ER32	50	100	16	50	AK	M6 - M28	UM/ER32



UM/ER32 = M40 x 1,5

#### Gewindeschneidfutter ER16 / ER25 kugellagert, längere Bauform

#### Tap Holders ER16 / ER25 Ball Bearing Guided, Longer Type

Ausführungen:

*Versions:*

WD: Spannfläche durchgehend

WD: *Clamping flat throughout*

Halter mit äußerer Kühlmittelzufuhr AK  
und abgesetzter Spannfläche FL

*Holder with inner coolant AK*

*and enclosed clamping flat FL*

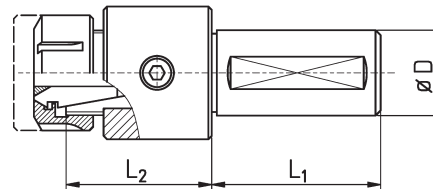
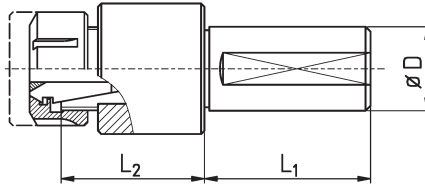

Bestell-Nr. order-no.	Zange collet	D	L <sub>1</sub>	L <sub>2</sub>	AK
GKUL161946	ER16	3/4"	46	53	--
GKUL161970AKFL	ER16	3/4"	70	53	AK
GKUL162046	ER16	20	46	53	--
GKUL162050AKFL	ER16	20	50	53	AK
GKUL162270AKFL	ER16	22	70	53	AK
GKUL162550AKFL	ER16	25	50	53	AK
GKUL1625100AKFL	ER16	25	100	53	AK
GKUL162650AKFL	ER16	1"	50	53	AK

Bestell-Nr. order-no.	Zange collet	D	L <sub>1</sub>	L <sub>2</sub>	AK
GKUL251946	ER25	3/4"	46	53	--
GKUL251970AKFL	ER25	3/4"	70	53	AK
GKUL252046	ER25	20	46	53	--
GKUL252050AKFL	ER25	20	50	53	AK
GKUL252270AKFL	ER25	22	70	53	AK
GKUL252550AKFL	ER25	25	50	53	AK
GKUL2525100AKFL	ER25	25	100	53	AK
GKUL252650	ER25	1"	50	53	--
GKUL254087WD	ER25	40	87	15	--



UM/ER16 = M22 x 1,5



UM/ER25 = M32 x 1,5

## VDI-Gewindeschneidfutter ER

Kugellagert, mit innerer Kühlmittelzufuhr

- Längenausgleich auf Zug 10 mm
- zusätzlich mit Andruck als Sonderausführung
- Lieferbar auch mit: - Kugellagermutter  
- Mitnehmer

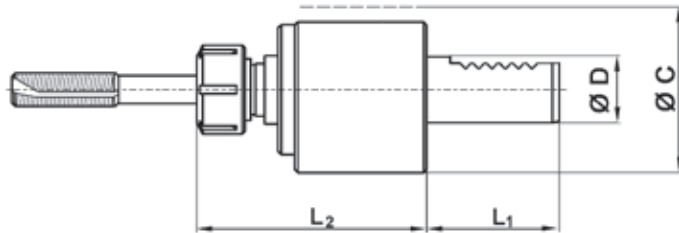

- Pullout 10 mm
- Special version for pullout and compression available
- Available with: - ball bearing nut  
- driver

Bestell-Nr. order-no.	Zange collet	D	L <sub>1</sub>	L <sub>2</sub>	C	Bereich range	Mutter Nut	Schlüssel spanner
GKU16V16	ER16	16	32	67	40	M1 - M8	UM/ER16	GS 25
GKU16V20	ER16	20	40	63	50	M1 - M8	UM/ER16	GS25
GKU16V20 DZ	ER16	20	40	63	50	M1 - M8	UM/ER16	GS 25
GKU16V50	ER16	50	72	59	98	M1 - M8	UM/ER16	GS 25
GKU25V16	ER25	16	32	73	40	M3 - M20	UM/ER25	E 25
GKU25V20 DZ	ER25	20	40	63	50	M3 - M20	UM/ER25	E 25
GKU25V30	ER25	30	55	68	68	M3 - M20	UM/ER25	E 25
GKU25V40AK	ER25	40	63	56	83	M3 - M20	UM/ER25	E 25
GKU25V50	ER25	50	72	59	98	M3 - M20	UM/ER25	E 25
GKU32V30	ER32	30	55	50	68	M6 - M28	UM/ER32	E 32
GKU32V40	ER32	40	63	43	83	M6 - M28	UM/ER32	E 32
GKU32V50	ER32	50	78	42	98	M6 - M28	UM/ER32	E 32

DZ = Druck und Zug

DZ = compression and pullout



UM/ER16 = M22 x 1,5



UM/ER25 = M32 x 1,5



UM/ER32 = M40 x 1,5

**Gewindebohrerhalter, kugelgeführt  
zum Gewindenachschnitten für Rechts- und Linksgewinde**

**Tap Holders, Ball Bearing Guided  
For Re-tapping Right and Left Hand Thread**

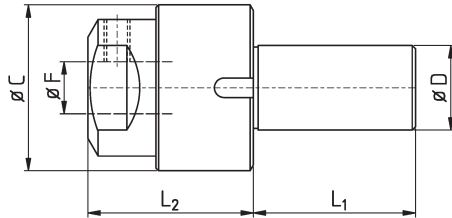

Bestell-Nr. order-no.	Maschine machine	Orig. Ersatzteil-Nr. orig. spare part no.	D	L <sub>1</sub>	L <sub>2</sub>	C	F
U270.50.15-12K		W14 521	3/4"	46	35	44	12
U270.50.15-15K		W14 521	3/4"	46	35	44	15
U270.50.20-12K	Index 12 - 18 - 25 Index C19 - 29/8L	W14 510.0046	3/4"	46	41	44	12
U270.50.20-15K		Traub 315 080					
U270.50.20-15K		W14 510.0046	3/4"	46	41	44	15
U270.50.20		Traub 315 080	3/4"	46	42	44	12
U270.50.25		W14	3/4"	50	51	50	15
U270.50.35	Traub TD 16 - 36	Traub 315 033	3/4"	45	52	50	25
U270.60.30	Index B30-42-60-60F/8L Index C19 - 29/6L Index ER 30-42-60-100 Index ER 30-42-60/iL	W34 510.00	1"	46	52	53,5	18

**Weitere Schaft-Ø lieferbar:** 5/8" 16,0 20,0 22,0 25,0 30,0 1 1/4" 32,0  
*Other shank-Ø available:*





## Doppel - Gewindeschneidfutter *Double Ended Tap Holders*



## Doppel-Gewindeschneidfutter

beidseitiger Auszug, für CNC-Maschinen mit Abgreifspindel (CITIZEN, MANUHRIN, STAR)

## Double Ended Tap Holders

Non Reversing Both Ends for CNC-Machines with Sub Spindle (CITIZEN, MANUHRIN, STAR)

Einsätze - inserts							
Bezeichnung title	Zange collet	$L_2 / L_3$	Bereich range	Mutter nut	A	Gewinde thread	Schlüssel spanner
U11	ER11	9	M1 - M6	UM/ER11	19	M14x0,75	GS17
M11	ER11	10	M1 - M6	ER11M	16	M13x0,75	E11M
U16	ER16	19	M1 - M8	UM/ER16	28	M22x1,5	GS25
M16	ER16	19	M1 - M8	ER16M	22	M19x1	E16M



ER11M = M13 x 0,75



ER16M = M19 x 1



UM/ER11 = M14 x 0,75



UM/ER16 = M22 x 1,5

Beliebige Kombinationsmöglichkeiten! - Any possible combinations!

z. B. 2 gleiche Zangen (und Muttern)

For example 2 identical collets (and nuts)

oder unterschiedliche Zangen (und Muttern)

or different collets (and nuts)

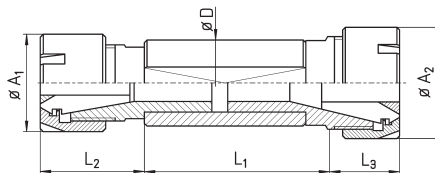

Bestell-Schlüssel - Key to order:

GD	Einsatz 1 insert 1	Einsatz 2 insert 2	Halter holder
----	-----------------------	-----------------------	------------------

BEISPIEL - EXAMPLE:

GD M11 M16 2240



Halter - holders		
Bezeichnung title	D	$L_1$
1642WD	16	42
1650WD	16	50
16100FL	16	100
1945FL	3/4"	45
1950FL	3/4"	50
2048FL	20	48
2055FL	20	55
2060FL	20	60
2240	22	40
2246FL	22	46
2248FL	22	48
2257WD	22	57
2260FL	22	60
2275FL	22	75
2285WD	22	85
2285FL	22	85
2295WD	22	95
22100WD	22	100
2360WD	23	60
2545WD	25	45
2546FL	25	46
2562WD	25	62
2570	25	70
2570FL	25	70
2646FL	1"	46
2670	1"	70
3265WD	32	65

Alle Gewindeschneidfutter werden incl. Standard-Mutter geliefert - all tap holders will be supplied with clamping Nut (standard)  
Auf alle Doppel-Gewindeschneidfutter passen unsere Schneisenköpfe - all double tap holders can be also used for button die holders

#### Zangenspannfutter-Gewindeschneidfutter

- 1. Seite: Feste Zangenaufnahme
- 2. Seite: Gewindeschneidfutter

#### Collet Holders-Tap Holders

- Side 1: Drill Holder
- Side 2: Tap Holder

Einsätze - inserts							
Bezeichnung title	Zange collet	L <sub>2</sub>	Bereich range	Mutter nut	A	Gewinde thread	Schlüssel spanner
U11	ER11	9	M1 - M6	UM/ER11	19	M14x0,75	GS17
M11	ER11	10	M1 - M6	ER11M	16	M13x0,75	E11M
U16	ER16	19	M1 - M8	UM/ER16	28	M22x1,5	GS25
M16	ER16	19	M1 - M8	ER16M	22	M19x1	E16M



ER11M = M13 x 0,75



ER16M = M19 x 1



UM/ER11 = M14 x 0,75



UM/ER16 = M22 x 1,5



Jeder Halter kann mit jedem Einsatz kombiniert werden  
*Each holder can be combined with each insert*

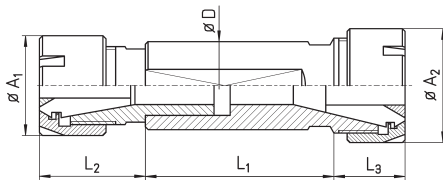

#### Bestell-Schlüssel - key to order:

GE	Einsatz insert	Halter holder
----	-------------------	------------------

#### BEISPIEL - EXAMPLE:

GEM11	M162270FL
-------	-----------

Halter - holders					
feste Seite - drill holder					
Bezeichnung title	Zange collet	Mutter nut	D	L <sub>1</sub>	L <sub>3</sub>
M111630WD	ER11	ER11M	16	30	13
M111640WD	ER11	ER11M	16	40	13
M161950FL	ER16	ER16M	3/4"	50	16
M161970FL	ER16	ER16M	3/4"	70	16
M162050FL	ER16	ER16M	20	50	16
M162070FL	ER16	ER16M	20	70	16
M162250FL	ER16	ER16M	22	50	16
M162270FL	ER16	ER16M	22	70	16
M1622100WD	ER16	ER16M	22	100	16
M1622120FL	ER16	ER16M	22	120	16
M162550WD	ER16				
M162570FL	ER16	ER16M	25	70	16
M162650WD	ER16	ER16M	1"	50	16
M162670WD	ER16	ER16M	1"	70	16
U112032FL	ER11	UM/ER11	20	32	13
U112055FL	ER11	UM/ER11	20	55	13
U112255FL	ER11	UM/ER11	22	55	13

Alle Gewindeschneidfutter werden incl. Standard-Mutter geliefert - holders will be supplied with clamping Nut (standard)  
 Auf alle Doppel-Gewindeschneidfutter passen unsere Schneideisenköpfe - All double tap holders can be also used for button die holders