

Zangenspannfutter *Collet Holders*

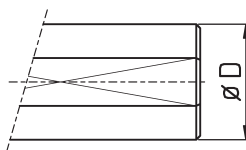
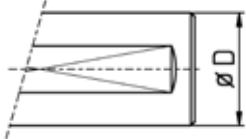

passion for clamping

- Alle Zangenspannfutter werden incl. Standard-Mutter geliefert
 - Zangenspannfutter mit "AK" werden incl. abgedichteter Mutter (System Rego-fix) geliefert.
 - Rundlaufgenauigkeit der ER Zangenspannfutter < 5 μ
 - Abkürzungen bei den Halter-Bezeichnungen:
- All holders will be supplied with clamping nut (standard)
 - Holders with "AK" will be supplied with sealed nut type Rego-fix
 - Runout accuracy ER-collet holders < 5 μ
 - List of abbreviations:

IK	axialer Kühlmittelanschluss		<i>axial inner coolant inlet</i>
AK	seitlicher (radialer) Kühlmittelanschluss		<i>radial inner coolant inlet</i>
WD	durchgehende Spannfläche		<i>throughout flat</i>
FL	abgesetzte Spannfläche		<i>no throughout flat</i>
T	speziell für Tornos Maschinen		<i>especially for TORNOS machines</i>
OS	ohne Anschlagsschraube		<i>without inner stop screw</i>

	Gewinde des Kühlmittelanschlusses:	<i>Thread inner coolant lead in:</i>
AK0	M12 x 1,5	
AK1	G 1/8"	
AK2	M8 x 1	
AK3	M10 x 1	

- **B = kleinster Durchmesser**
B = smallest diameter
- Umfangreiches Spannzangen-Sortiment in unserem Katalog
"Werkstück- und Werkzeugspannung"
Large assortment of collets see our catalog "Workpiece and Tool Clamping"



■ Überstandsmaße von Muttern bei Zangenspannfutter

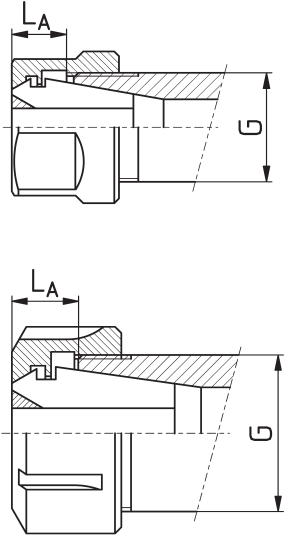

■ Collet holders: Overlap of nuts

Mutter nut	G	LA
ER08M	M10x0,75	4,3 - 6,1
ER11M	M13x0,75	5,7 - 7,5
ER16M	M19x1	8 - 11,5
ER20M	M24x1	8 - 11,5
ER25M	M30x1	8,5 - 12
UM/ER11	M14x0,75	4,9 - 6,6
UM/ER16	M22x1,5	7 - 10,5
UM/ER20	M25x1,5	8 - 11,5
UX/ER16	M22x1,5	7 - 10,5
UX/ER20	M25x1,5	8 - 11,5
UM/ER25	M32x1,5	8,5 - 12
UM/ER32	M40x1,5	9,5 - 13
UM/ER40	M50x1,5	11,5 - 15
UM/ER50	M64x2,0	14 - 21

■ Alle Halter AK0 können auf AK1 - AK3 reduziert werden

■ IK-Reduzierungen:

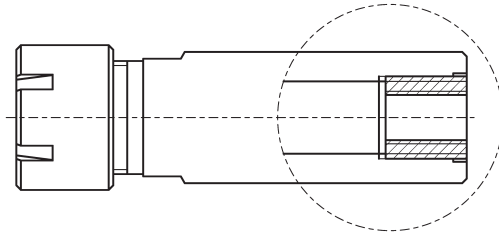

■ All holders AK0 can be reduced to AK1 - AK3

■ inner coolant (IK):



Anwendungsbeispiel - example

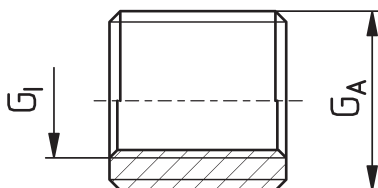

Bestell-Nr. order-no.	GA	GI
RED1/4 - 1/8	G1/4"	G1/8"
RED1/4 - M10x1	G1/4"	M10 x 1
RED1/4 - M8x1	G1/4"	M8 x 1
RED1/8 - M8x1	G1/8"	M8 x 1
REDM12x1,5 - G1/8	M12 x 1,5	G1/8"
REDM12x1,5 - M10x1	M12 x 1,5	M10 x 1
REDM12x1,5 - M8x1	M12 x 1,5	M8 x 1
RED1/8 - 1/8NPT	G1/8"	1/8"NPT
REDM8x1 - 1/8NPT	M8 x 1	1/8"NPT

ER-Zangenspannfutter ER08M

ER-Collet Holders ER08M

Ausführungen:

Versions:

Vgl. auch S. 4 + 5

See also page 4 + 5



Bild 1 (WD)



Bild 2 (FL)

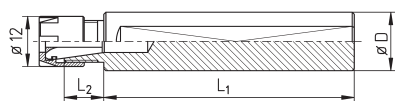

Bild 3 (B)



Bild 4 (IK)

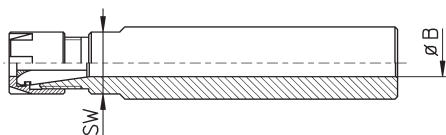

ER08M = M10 x 0,75

Abbildungen können abweichen - catalog drawings may differ

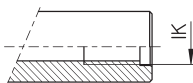
Bestell-Nr. order-no.	Zange collet	D	L ₁	L ₂	IK / B ic / B	SW	Bild picture	Mutter nut	Schlüssel spanner
EM080570	ER08	5	68	15,5	-	8	1*	ER08M	E08M
EM080635	ER08	6	35	24	-	12	1*	ER08M	E08M
EM080670	ER08	6	70	17	-	8	1*	ER08M	E08M
EM080820B-Sonder	ER08	8	18	13	3	-	3*	ER08M	E08M
EM080855	ER08	8	55	17,5	-	9	1*	ER08M	E08M
EM080870	ER08	8	70	16	-	8	1*	ER08M	E08M
EM0808120	ER08	8	118	16	-	8	1*	ER08M	E08M
EM0808125	ER08	8	125	16	-	8	1*	ER08M	E08M
EM0808125WD	ER08	8	125	16	-	8	1	ER08M	E08M
EM081015	ER08	10	15	12	-	9,5	1*	ER08M	E08M
EM081082FL	ER08	10	82	8	-	8	1 / 2	ER08M	E08M
EM081084	ER08	10	84	8	5	8	1*	ER08M	E08M
EM0810120	ER08	10	118	8	-	8	1*	ER08M	E08M
EM0810120FL	ER08	10	118	8	-	8	1 / 2	ER08M	E08M
EM081245	ER08	12	45	9,5	-	10	1*	ER08M	E08M
EM081245FL	ER08	12	45	9,5	-	10	1 / 2	ER08M	E08M
EM081280	ER08	12	80	8	-	10	1*	ER08M	E08M
EM081280FL	ER08	12	80	8	-	10	1 / 2	ER08M	E08M
EM0812125	ER08	12	125	9,5	-	10	1*	ER08M	E08M
EM0812125FL	ER08	12	125	9,5	-	10	1 / 2	ER08M	E08M
EM0812138	ER08	12	138	11	6	12	3*	ER08M	E08M
EM0812140	ER08	12	140	10	-	10	1*	ER08M	E08M
EM0812150	ER08	12	150	9,5	6	10	3*	ER08M	E08M
EM0812200	ER08	12	200	9	-	10	1*	ER08M	E08M
EM081460WD	ER08	14	60	10	7	12	3	ER08M	E08M
EM081460IKWD	ER08	14	60	10	M8x1	12	4	ER08M	E08M
EM085830WD	ER08	5/8"	30	9	7	14	3	ER08M	E08M
EM085845WD	ER08	5/8"	45	11	5	14	3	ER08M	E08M
EM081645	ER08	16	45	9,5	7	14	3*	ER08M	E08M
EM081645WD	ER08	16	45	9,5	7	14	3	ER08M	E08M

* = ohne Spannfläche - without flat

ER-Zangenspannfutter ER11M

ER-Collet Holders ER11M

Ausführungen:

Versions:

Vgl. auch S. 4 + 5

See also page 4 + 5



Bild 1 (WD)

Bild 2 (FL)



Bild 3 (B)

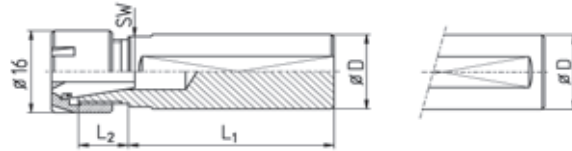

Bild 4 (IK)

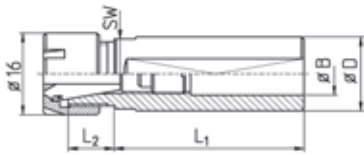

ER11M = M13 x 0,75

Abbildungen können abweichen - catalog drawings may differ

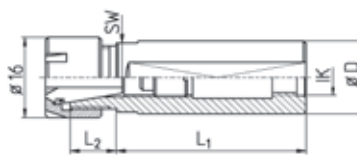
Bestell-Nr. order-no.	Zange collet	D	L ₁	L ₂	IK / B ic / B	SW	Bild picture	Mutter nut	Schlüssel spanner
EM110554	ER11	5	54	23	-	11	1*	ER11M	E11M
EM110655	ER11	6	55	20	-	11	1*	ER11M	E11M
EM110756	ER11	7	56	20	-	11	1*	ER11M	E11M
EM110856	ER11	8	56	20	-	11	1*	ER11M	E11M
EM1108100	ER11	8	100	21	-	11	1*	ER11M	E11M
EM111060FL	ER11	10	60	21	-	11	1 / 2	ER11M	E11M
EM111060	ER11	10	60	20	-	11	1*	ER11M	E11M
EM111080	ER11	10	80	20	-	11	1*	ER11M	E11M
EM111080FL	ER11	10	80	20	-	11	1 / 2	ER11M	E11M
EM1110120	ER11	10	120	20	-	11	1*	ER11M	E11M
EM1110125	ER11	10	125	21	-	11	1*	ER11M	E11M
EM111240	ER11	12	40	20	7	11	3*	ER11M	E11M
EM111240FL	ER11	12	40	18	-	11	1 / 2	ER11M	E11M
EM111240WD	ER11	12	40	18	-	11	1	ER11M	E11M
EM111280	ER11	12	80	17	-	11	1*	ER11M	E11M
EM111280FL	ER11	12	80	17	-	11	1 / 2	ER11M	E11M
EM1112124	ER11	12	124	20	-	11	1*	ER11M	E11M
EM1112125FL	ER11	12	125	17	-	11	1 / 2	ER11M	E11M
EM1112150	ER11	12	150	18	-	11	1*	ER11M	E11M
EM1112150FL	ER11	12	150	18	-	11	1 / 2	ER11M	E11M
EM111370	ER11	1/2"	70	18	-	11	1*	ER11M	E11M
EM111420	ER11	14	20	12	7,5	12	3*	ER11M	E11M
EM111420WD	ER11	14	20	12	7,5	12	3	ER11M	E11M
EM115850IK	ER11	5/8"	50	12	G1/8"	14	4*	ER11M	E11M
EM115850IKWD	ER11	5/8"	50	12	G1/8"	14	4	ER11M	E11M
EM115880	ER11	5/8"	80	11	8	14	3*	ER11M	E11M
EM1158125IKFL	ER11	5/8"	125	12	G1/8"	14	2 / 4	ER11M	E11M
EM111620	ER11	16	20	12	7	14	3*	ER11M	E11M
EM111620FL	ER11	16	20	12	7	14	2 / 3	ER11M	E11M
EM111620WD	ER11	16	20	12	7	14	3	ER11M	E11M
EM111630	ER11	16	30	12	8,5	14	3*	ER11M	E11M
EM111630WD	ER11	16	30	12	8,5	14	3	ER11M	E11M
EM111636IKWD	ER11	16	36	12	G1/8"	14	4	ER11M	E11M

* = ohne Spannfläche - without flat

Bestell-Nr. order-no.	Zange collet	D	L ₁	L ₂	IK / B ic / B	SW	Bild picture	Mutter nut	Schlüssel spanner
EM111655	ER11	16	55	12	8	14	3*	ER11M	E11M
EM111655IKWD	ER11	16	55	12	G1/8"	14	4	ER11M	E11M
EM111675IKTWD	ER11	16	75	15	G1/8"	14	4	ER11M	E11M
EM111680	ER11	16	80	12	8	14	3*	ER11M	E11M
EM111680IKFL	ER11	16	80	12	G1/8"	14	2 / 4	ER11M	E11M
EM111698IKWD	ER11	16	98	15	G1/8"	14	4	ER11M	E11M
EM1116100	ER11	16	100	13	-	14	1*	ER11M	E11M
EM1116125	ER11	16	125	12	6	14	3*	ER11M	E11M
EM1116125FL	ER11	16	125	12	6	14	2 / 3	ER11M	E11M
EM1116140	ER11	16	140	12	-	14	1*	ER11M	E11M
EM1116140FL	ER11	16	140	12	-	14	1 / 2	ER11M	E11M
EM1116150IKTWD	ER11	16	148	16	G1/8"	14	4	ER11M	E11M
EM1116150	ER11	16	150	12	6	14	3*	ER11M	E11M
EM1116150M	ER11	16	150	12	-	14	1*	ER11M	E11M
EM1116150MFL	ER11	16	150	12	-	14	1 / 2	ER11M	E11M
EM1116150FL	ER11	16	150	12	6	14	2 / 3	ER11M	E11M
EM1116160	ER11	16	160	15,5	8	14	3*	ER11M	E11M
EM1116180	ER11	16	180	12	-	14	1*	ER11M	E11M
EM1116220	ER11	16	220	13	-	14	1*	ER11M	E11M
EM1116250	ER11	16	250	13	-	14	1*	ER11M	E11M
EM1118115FL-Special	ER11	18	114	11	-	-	1 / 2	ER11M	E11M
EM1118310	ER11	18	310	12	-	15	1*	ER11M	E11M
EM1118330	ER11	18	330	13	-	15	1*	ER11M	E11M
EM111950IK	ER11	3/4"	50	13	G1/8"	17	4*	ER11M	E11M
EM111950IKWD	ER11	3/4"	50	12	G1/8"	17	4	ER11M	E11M
EM111960WD	ER11	3/4"	60	12	8,5	17	3	ER11M	E11M
EM111970IK	ER11	3/4"	70	12	G1/8"	17	4*	ER11M	E11M
EM111970IKFL	ER11	3/4"	70	12	G1/8"	17	2 / 4	ER11M	E11M
EM111970IKWD	ER11	3/4"	70	12	G1/8"	17	4	ER11M	E11M
EM1119100	ER11	3/4"	100	13	-	17	1*	ER11M	E11M
EM1119115FL-Special	ER11	3/4"	114	11	-	-	1 / 2	ER11M	E11M
EM112060IK	ER11	20	60	12	G1/8"	17	4*	ER11M	E11M
EM112060IKWD	ER11	20	60	12	G1/8"	17	4	ER11M	E11M
EM112090IKWD	ER11	20	90	11	G1/8"	17	4	ER11M	E11M
EM1120100	ER11	20	100	12	-	17	1*	ER11M	E11M
EM1120100IK	ER11	20	100	12	G1/4"	17	4*	ER11M	E11M
EM1120100IKWD	ER11	20	100	12	G1/4"	17	4	ER11M	E11M
EM1120240	ER11	20	240	12	-	17	1*	ER11M	E11M
EM1120240WD	ER11	20	240	12	-	17	1	ER11M	E11M
EM112270IKWD	ER11	22	70	12	G1/8"	19	4	ER11M	E11M
EM112290IKOSWD**	ER11	22	90	12	G1/4"	-	4	ER11M	E11M
EM112290IKOS**	ER11	22	90	12	G1/4"	-	4*	ER11M	E11M
EM1122120IKOS	ER11	22	120	12,5	G1/8"	-	4*	ER11M	E11M
EM1122120IKOSWD	ER11	22	120	12	G1/8"	-	4	ER11M	E11M
EM1122120WD	ER11	22	120	12	7	19	3	ER11M	E11M
EM1132125	ER11	22	125	11	-	27	1*	ER11M	E11M

* = ohne Spannfläche - without flat

** = ohne Schlüsselfläche - without spanner flat

ER-Zangenspannfutter ER16M

ER-Collet Holders ER16M

Ausführungen:

Versions:

Vgl. auch S. 4 + 5

See also page 4 + 5



Bild 1 (WD)

Bild 2 (FL)



Bild 3 (B)

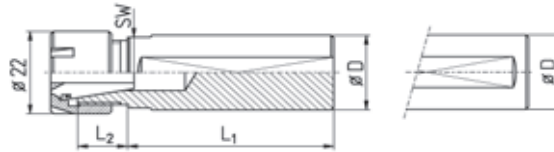

Bild 4 (IK)

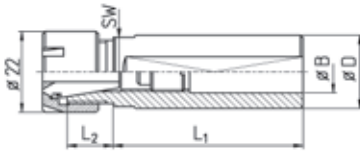

ER16M = M19 x 1

Abbildungen können abweichen - *catalog drawings may differ*

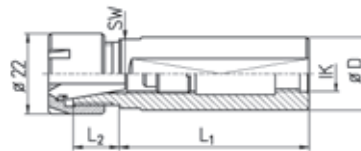
Bestell-Nr. order-no.	Zange collet	D	L ₁	L ₂	IK / B ic / B	SW	Bild picture	Mutter nut	Schlüssel spanner
EM160860	ER16	8	60	27	-	17	1*	ER16M	E16M
EM161060	ER16	10	60	25	-	19	1*	ER16M	E16M
EM161224	ER16	12	24	26	8	17	3*	ER16M	E16M
EM161280	ER16	12	80	26	-	17	1*	ER16M	E16M
EM1613100	ER16	1/2"	100	27	-	17	1*	ER16M	E16M
EM161418IKFL	ER16	14	18	25	M8x1	17	2 / 4	ER16M	E16M
EM161418IK	ER16	14	18	22	M8x1	17	4*	ER16M	E16M
EM161530FL	ER16	15	30	25	9	17	2 / 3	ER16M	E16M
EM161590	ER16	15	90	20	-	17	1*	ER16M	E16M
EM165835	ER16	5/8"	35	25	9	17	3*	ER16M	E16M
EM165835FL	ER16	5/8"	35	25	9	17	2 / 3	ER16M	E16M
EM1658125	ER16	5/8"	125	25	9	17	3*	ER16M	E16M
EM161620FL	ER16	16	20	25	9	17	2 / 3	ER16M	E16M
EM161630	ER16	16	30	25	10	17	3*	ER16M	E16M
EM161630FL	ER16	16	30	25	10	17	2 / 3	ER16M	E16M
EM161635	ER16	16	35	25	10	17	3*	ER16M	E16M
EM161635FL	ER16	16	35	25	10	17	2 / 3	ER16M	E16M
EM161670IK	ER16	16	70	25	G1/8"	17	4*	ER16M	E16M
EM161670FL	ER16	16	70	25	10	17	2 / 3	ER16M	E16M
EM161680IK	ER16	16	80	27	G1/8"	17	4*	ER16M	E16M
EM161680FL	ER16	16	80	27	9	17	2 / 3	ER16M	E16M
EM1616100	ER16	16	100	25	8,5	17	3*	ER16M	E16M
EM1616100FL	ER16	16	100	25	9	17	2 / 3	ER16M	E16M
EM1616150IK	ER16	16	150	25	G1/8"	17	4*	ER16M	E16M
EM1616150FL	ER16	16	150	25	-	17	2 / 3	ER16M	E16M
EM1616160	ER16	16	160	27	8,5	17	3*	ER16M	E16M
EM1616160FL	ER16	16	160	27	8,5	17	2 / 3	ER16M	E16M
EM1618110IKWD	ER16	18	110	25	G1/8"	17	3	ER16M	E16M
EM1618280	ER16	18	280	25	-	15	1*	ER16M	E16M
EM1618280IK	ER16	18	280	25	G1/8"	17	4*	ER16M	E16M
EM1618320	ER16	18	320	25	-	17	1*	ER16M	E16M
EM161940IK	ER16	3/4"	39	13	G1/4"	17	4*	ER16M	E16M
EM161940IKFL	ER16	3/4"	40	13	G1/4"	17	2 / 4	ER16M	E16M
EM161950IK	ER16	3/4"	52	12	G1/8"	17	4*	ER16M	E16M
EM161950IKFL	ER16	3/4"	51,5	13	G1/4"	17	2 / 4	ER16M	E16M

* = ohne Spannfläche - *without flat*

Bestell-Nr. order-no.	Zange collet	D	L ₁	L ₂	IK / B ic / B	SW	Bild picture	Mutter nut	Schlüssel spanner
EM161972IKFL	ER16	3/4"	72	13	G1/4"	17	2 / 4	ER16M	E16M
EM161972IKWD	ER16	3/4"	72	13	G1/4"	17	4	ER16M	E16M
EM161972IK	ER16	3/4"	72	14	G1/4"	17	4*	ER16M	E16M
EM1619100IKFL	ER16	3/4"	102	13	G1/4"	17	2 / 4	ER16M	E16M
EM1619100	ER16	3/4"	100	13	12	17	3*	ER16M	E16M
EM1619120IK	ER16	3/4"	120	13	G1/8"	17	4*	ER16M	E16M
EM1619120FL	ER16	3/4"	120	15	11,5	17	2 / 3	ER16M	E16M
EM1619120IKWD	ER16	3/4"	121	13	G1/8"	17	4	ER16M	E16M
EM1619140	ER16	3/4"	140	13	11	17	3*	ER16M	E16M
EM1619200	ER16	3/4"	203	12	-	17	1*	ER16M	E16M
EM162038IK	ER16	20	38	16	G1/4"	17	4*	ER16M	E16M
EM162038IKFL	ER16	20	38	16	G1/4"	17	2 / 4	ER16M	E16M
EM162038WD	ER16	20	38	16	10	17	3	ER16M	E16M
EM162050	ER16	20	50	13,5	11	17	3*	ER16M	E16M
EM162050FL	ER16	20	50	14	11	17	2 / 3	ER16M	E16M
EM162070	ER16	20	70	16	11	17	3*	ER16M	E16M
EM162070FL	ER16	20	70	13	11	17	2 / 3	ER16M	E16M
EM162070IKFL	ER16	20	70	13	G1/4"	17	2 / 4	ER16M	E16M
EM162070IKWD	ER16	20	70	15	G1/4"	17	4	ER16M	E16M
EM1620100FL	ER16	20	100	15	10	19	2 / 3	ER16M	E16M
EM1620100IKFL	ER16	20	100	16	G1/4"	17	2 / 4	ER16M	E16M
EM1620100IK	ER16	20	100	16	G1/4"	17	4*	ER16M	E16M
EM1620100IKWD	ER16	20	100	16	G1/4"	17	4	ER16M	E16M
EM1620120	ER16	20	120	16	11	17	3*	ER16M	E16M
EM1620120FL	ER16	20	120	15	10	17	2 / 3	ER16M	E16M
EM1620140	ER16	20	140	16	11	17	3*	ER16M	E16M
EM1620140FL	ER16	20	140	16	11	17	2 / 3	ER16M	E16M
EM1620150IK	ER16	20	148	22	G1/8"	17	4*	ER16M	E16M
EM1620150IKWD	ER16	20	148	22	G1/8"	17	4	ER16M	E16M
EM1620170FL	ER16	20	170	15	11	17	2 / 3	ER16M	E16M
EM1620170	ER16	20	170	15	12	17	3*	ER16M	E16M
EM1620200	ER16	20	200	15	8	17	3*	ER16M	E16M
EM1620200FL	ER16	20	200	15	8	17	2 / 3	ER16M	E16M
EM162238IKWD	ER16	22	38	16	G1/4"	19	4	ER16M	E16M
EM162246WD #	ER16	22	46	16	10,5	-	3	ER16M	E16M
EM162250WD	ER16	22	50	16	12	19	3	ER16M	E16M
EM162250IKWD	ER16	22	50	16	G1/8"	19	4	ER16M	E16M
EM162270IK	ER16	22	70	16	G1/4"	19	4*	ER16M	E16M
EM162270IKFL	ER16	22	70	16	G1/4"	19	2 / 4	ER16M	E16M
EM162270IKWD	ER16	22	70	16	G1/4"	19	4	ER16M	E16M
EM162290IK	ER16	22	90	16	G1/4"	19	4*	ER16M	E16M
EM162290IKWD	ER16	22	90	16	G1/8"	19	4	ER16M	E16M
EM1622100	ER16	22	100	16	-	19	1*	ER16M	E16M
EM1622105IKWD	ER16	22	105	16	G1/8"	19	4	ER16M	E16M
EM1622114IKWD	ER16	22	114	16	G1/8"	19	4	ER16M	E16M
EM1622120IKFL	ER16	22	120	16	G1/8"	19	2 / 4	ER16M	E16M
EM1622120IK	ER16	22	120	16	G1/8"	19	4*	ER16M	E16M
EM1622140IK	ER16	22	140	16	G1/8"	19	4*	ER16M	E16M
EM1622140IKWD	ER16	22	140	16	G1/8"	19	4	ER16M	E16M
EM162370IKWD	ER16	23	70	16	G1/4"	19	4	ER16M	E16M

* = ohne Spannfläche - without flat

für STAR SR20RIV (mit Bund und Nut für Dichtring, Spannfläche schräg zulaufend)
for STAR SR20RIV (with flange and groove for sealing, clamping flat aslope)

Bestell-Nr. order-no.	Zange collet	D	L ₁	L ₂	IK / B ic / B	SW	Bild picture	Mutter nut	Schlüssel spanner
EM162560IK	ER16	25	60	16	G1/4"	22	4*	ER16M	E16M
EM162560IKFL	ER16	25	60	16	G1/4"	22	2 / 4	ER16M	E16M
EM162560IKWD	ER16	25	60	16	G1/4"	22	4	ER16M	E16M
EM162575	ER16	25	75	16	-	22	1*	ER16M	E16M
EM162575IK	ER16	25	75	16	G1/4"	22	4*	ER16M	E16M
EM162575IKWD	ER16	25	75	16	G1/4"	22	4	ER16M	E16M
EM1625100IK	ER16	25	100	16	G1/4"	22	4*	ER16M	E16M
EM1625100IKWD	ER16	25	100	16	G1/4"	22	4	ER16M	E16M
EM1625150IK	ER16	25	150	16	M14x1,5	22	4*	ER16M	E16M
EM1625150IKTWD	ER16	25	150	16	M14x1,5	22	4	ER16M	E16M
EM162638WD	ER16	1"	38	16	12	22	3	ER16M	E16M
EM162638FL	ER16	1"	38	16	12	22	2 / 3	ER16M	E16M
EM162638	ER16	1"	38	16	10	22	3*	ER16M	E16M
EM162650IKFL	ER16	1"	50	16	G1/4"	22	2 / 4	ER16M	E16M
EM162660	ER16	1"	60	16	12	22	3*	ER16M	E16M
EM162660FL	ER16	1"	60	16	12	22	2 / 3	ER16M	E16M
EM162660IKWD	ER16	1"	60	16	G1/4"	22	4	ER16M	E16M
EM162665FL	ER16	1"	65	16	12	22	2 / 3	ER16M	E16M
EM162672IKWD	ER16	1"	72	16	G1/4"	22	4	ER16M	E16M
EM162675IK	ER16	1"	75	16	G1/4"	22	4*	ER16M	E16M
EM162675FL	ER16	1"	75	15	11,5	22	2 / 3	ER16M	E16M
EM162675WD	ER16	1"	75	16	10	22	3	ER16M	E16M
EM1626100IK	ER16	1"	100	16	G1/4"	22	4*	ER16M	E16M
EM1626100FL	ER16	1"	100	15	12	22	2 / 3	ER16M	E16M
EM1626120FL	ER16	1"	120	16	12	22	2 / 3	ER16M	E16M
EM1626150IK	ER16	1"	150	16	G1/4"	22	4*	ER16M	E16M
EM1626150IKWD	ER16	1"	150	16	G1/4"	22	4	ER16M	E16M
EM162890IKWD	ER16	28	90	16	M12x1	24	4	ER16M	E16M

* = ohne Spannfläche - without flat

ER-Zangenspannfutter ER20M

ER-Collet Holders ER20M

Ausführungen:

Versions:

Vgl. auch S. 4 + 5

See also page 4 + 5



Bild 1 (WD)



Bild 2 (FL)

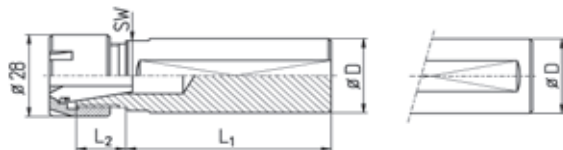

Bild 3 (B)

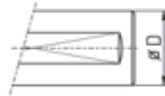

Bild 4 (IK)

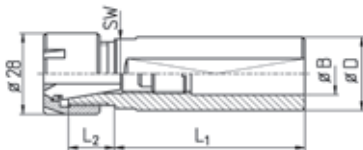

ER20M = M24 x 1

Abbildungen können abweichen - catalog drawings may differ

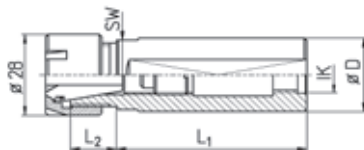
Bestell-Nr. order-no.	Zange collet	D	L ₁	L ₂	IK / B ic / B	SW	Bild picture	Mutter nut	Schlüssel spanner
EM2015100	ER20	15	100	32	-	22	1*	ER20M	E20M
EM201650	ER20	16	50	32	11	22	3*	ER20M	E20M
EM201650FL	ER20	16	50	32	11	22	2 / 3	ER20M	E20M
EM201650WD	ER20	16	50	32	11	22	3	ER20M	E20M
EM2016100	ER20	16	100	32	-	22	1*	ER20M	E20M
EM2016100FL	ER20	16	100	32	-	22	1 / 2	ER20M	E20M
EM201865	ER20	18	65	27	13,5	22	3*	ER20M	E20M
EM201870	ER20	18	70	28	11	22	3*	ER20M	E20M
EM201950	ER20	3/4"	50	25	12	22	3*	ER20M	E20M
EM201950IK	ER20	3/4"	50	25	G1/4"	22	4*	ER20M	E20M
EM201950FL	ER20	3/4"	50	25	12	22	2 / 3	ER20M	E20M
EM201970	ER20	3/4"	70	25	12	22	3*	ER20M	E20M
EM201970IK	ER20	3/4"	70	25	G1/4"	22	4*	ER20M	E20M
EM201970FL	ER20	3/4"	70	25	12	22	2 / 3	ER20M	E20M
EM201970IKFL	ER20	3/4"	70	25	G1/8"	22	2 / 4	ER20M	E20M
EM2019125IK	ER20	3/4"	125	25	G1/8"	22	4*	ER20M	E20M
EM2019125IKWD	ER20	3/4"	125	25	G1/8"	22	4	ER20M	E20M
EM202050	ER20	20	50	25	14	22	3*	ER20M	E20M
EM202050FL	ER20	20	50	25	13	22	2 / 3	ER20M	E20M
EM202064IKTWD	ER20	20	64	23	M12x1,5	22	4	ER20M	E20M
EM202085IK	ER20	20	85	25	M12x1,5	22	4*	ER20M	E20M
EM202085IKTWD	ER20	20	85	25	M12x1,5	22	4	ER20M	E20M
EM2020100	ER20	20	100	26	11	22	3*	ER20M	E20M
EM2020100FL	ER20	20	100	26	11	22	2 / 3	ER20M	E20M
EM2020110IKTWD	ER20	20	110	23	M12x1,5	22	4	ER20M	E20M
EM2020150IK	ER20	20	150	25	G1/4"	22	4*	ER20M	E20M
EM2020150IKWD	ER20	20	150	25	G1/4"	22	4	ER20M	E20M
EM202270IK	ER20	22	70	25	G1/4"	22	4*	ER20M	E20M
EM202270IKFL	ER20	22	70	25	G1/4"	22	2 / 4	ER20M	E20M
EM202270WD	ER20	22	70	25	14	22	3	ER20M	E20M
EM202270IKWD	ER20	22	70	25	G1/4"	22	4	ER20M	E20M
EM202290	ER20	22	90	25	12	22	3*	ER20M	E20M
EM202290IKWD	ER20	22	90	22	G1/4"	22	4	ER20M	E20M

* = ohne Spannfläche - without flat

Bestell-Nr. order-no.	Zange collet	D	L ₁	L ₂	IK / B ic / B	SW	Bild picture	Mutter nut	Schlüssel spanner
EM202550FL	ER20	25	50	16	15	22	2 / 3	ER20M	E20M
EM202550	ER20	25	50	16	15	22	3*	ER20M	E20M
EM202560WD	ER20	25	60	16	15	22	3	ER20M	E20M
EM202560IKWD	ER20	25	60	16	G1/4"	22	4	ER20M	E20M
EM202575	ER20	25	75	16	15	22	3*	ER20M	E20M
EM202575FL	ER20	25	75	16	15	22	2 / 3	ER20M	E20M
EM2025100IK	ER20	25	100	16	M14x1,5	22	4*	ER20M	E20M
EM2025100IKWD	ER20	25	100	16	G1/4"	22	4	ER20M	E20M
EM2025100FL	ER20	25	100	17	15	22	2 / 3	ER20M	E20M
EM2025100WD	ER20	25	100	16	15	22	3	ER20M	E20M
EM2025140IKFL	ER20	25	140	16	G1/4"	22	2 / 4	ER20M	E20M
EM2025140IK	ER20	25	140	16	G1/4"	22	4*	ER20M	E20M
EM2025150IKWD	ER20	25	150	16	M14x1,5	22	4	ER20M	E20M
EM2025150IKT	ER20	25	150	16	M14x1,5	22	4*	ER20M	E20M
EM2025170IKWD	ER20	25	169	16	G1/4"	22	4	ER20M	E20M
EM2025200IK	ER20	25	200	16	M14x1,5	22	4*	ER20M	E20M
EM2025200IKWD	ER20	25	200	16	G1/4"	22	4	ER20M	E20M
EM202638	ER20	1"	38	16	13	22	3*	ER20M	E20M
EM202638WD	ER20	1"	38	16	13	22	3	ER20M	E20M
EM202638FL	ER20	1"	38	16	13	22	2 / 3	ER20M	E20M
EM202638IKFL	ER10	1"	38	16	G1/4"	22	4	ER20M	E20M
EM202670IKWD	ER20	1"	70	16	G1/4"	22	4	ER20M	E20M
EM202675IK	ER20	1"	75	16	G1/4"	22	4*	ER20M	E20M
EM202675WD	ER20	1"	75	16	13	22	3	ER20M	E20M
EM202675IKFL	ER20	1"	75	16	G1/4"	22	2 / 4	ER20M	E20M
EM202682WD	ER20	1"	82	16	13	22	3	ER20M	E20M
EM2026100FL	ER20	1"	100	16	12	22	2 / 3	ER20M	E20M
EM2026100IK	ER20	1"	100	16	G1/4"	22	4*	ER20M	E20M
EM2026100IKWD	ER20	1"	100	16	G1/4"	22	4	ER20M	E20M
EM2026140FL	ER20	1"	140	17	15	22	2 / 3	ER20M	E20M
EM2026155IK	ER20	1"	155	17	M12x1,5	22	4*	ER20M	E20M
EM2026155IKWD	ER20	1"	155	17	M12x1,5	22	4	ER20M	E20M
EM202890IKWD	ER20	28	90	16	M12x1,5	24	4	ER20M	E20M
EM203250IKWD	ER20	32	50	17	G1/4"	27	4	ER20M	E20M
EM203255IKWD	ER20	32	55	17	G1/4"	27	4	ER20M	E20M
EM203280	ER20	32	80	17	15	27	3*	ER20M	E20M
EM203280IKWD	ER20	32	80	17	G1/8"	27	4	ER20M	E20M
EM203280WD	ER20	32	80	17	15	27	3	ER20M	E20M
EM203280IK	ER20	32	80	15	G1/4"	27	4*	ER20M	E20M
EM2032100IK	ER20	32	100	18	G1/4"	27	4*	ER20M	E20M
EM2032100IKWD	ER20	32	101	18	G1/4"	27	4	ER20M	E20M

* = ohne Spannfläche - without flat

ER-Zangenspannfutter ER25M

ER-Collet Holders ER25M

Ausführungen:
Versions:

Vgl. auch S. 4 + 5
See also page 4 + 5

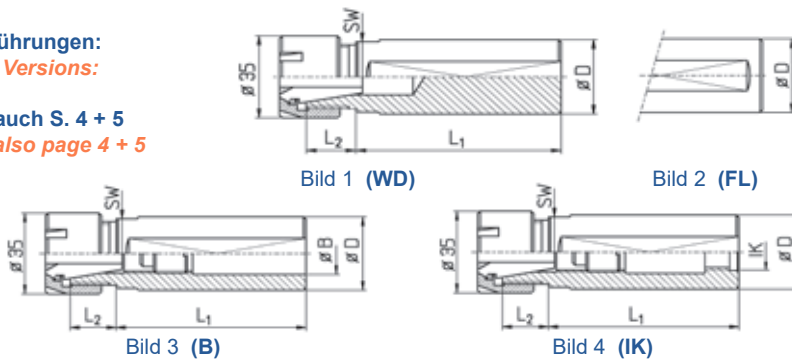

ER25M = M30 x 1

Abbildungen können abweichen - catalog drawings may differ

Bestell-Nr. order-no.	Zange collet	D	L ₁	L ₂	IK / B ic / B	SW	Bild picture	Mutter nut	Schlüssel spanner
EM251350	ER25	13	50	35	-	27	1*	ER25M	E25M
EM2516100FL	ER25	16	100	36	-	27	1 / 2	ER25M	E25M
EM2516100	ER25	16	100	36	-	27	1*	ER25M	E25M
EM251950	ER25	3/4"	50	33	12	27	3*	ER25M	E25M
EM251950FL	ER25	3/4"	50	33	12	27	2 / 3	ER25M	E25M
EM251970	ER25	3/4"	70	33	13	27	3*	ER25M	E25M
EM251974	ER25	3/4"	74	33	13	27	3*	ER25M	E25M
EM251974WD	ER25	3/4"	74	33	13	27	3	ER25M	E25M
EM252050IK	ER25	20	50	33	G1/4"	27	4*	ER25M	E25M
EM252050FL	ER25	20	50	33	14	27	2 / 3	ER25M	E25M
EM252075FL	ER25	20	75	33	14	27	2 / 3	ER25M	E25M
EM2520100	ER25	20	100	34	11	27	3*	ER25M	E25M
EM2520100FL	ER25	20	100	34	11,5	27	2 / 3	ER25M	E25M
EM2520150IK	ER25	20	150	33	G1/4"	27	4*	ER25M	E25M
EM2520150IKFL	ER25	20	150	33	G1/4"	27	2 / 4	ER25M	E25M
EM252275IK	ER25	22	75	27	G1/4"	27	4*	ER25M	E25M
EM252275FL	ER25	22	75	27	14	27	2 / 3	ER25M	E25M
EM252275IKFL	ER25	22	75	27	G1/4"	27	2 / 4	ER25M	E25M
EM252550IK	ER25	25	50	27	G1/4"	27	4*	ER25M	E25M
EM252550FL	ER25	25	50	27	18	27	2 / 3	ER25M	E25M
EM252575	ER25	25	75	27	17	27	3*	ER25M	E25M
EM252575FL	ER25	25	75	27	18	27	2 / 3	ER25M	E25M
EM2525100IKT	ER25	25	100	27	G1/4"	27	4*	ER25M	E25M
EM2525100WD	ER25	25	100	27	18	27	3	ER25M	E25M
EM2525100FL	ER25	25	100	27	18	27	2 / 3	ER25M	E25M
EM2525100IKWD	ER25	25	100	27	G1/4"	27	4	ER25M	E25M
EM2525150IK	ER25	25	150	27	M14x1,5	27	4*	ER25M	E25M
EM2525150IKTWD	ER25	25	150	27	M14x1,5	27	4	ER25M	E25M
EM2525180IK	ER25	25	180	27	G1/4"	27	4*	ER25M	E25M
EM2525180IKWD	ER25	25	180	27	G1/4"	27	4	ER25M	E25M
EM252675IKWD	ER25	1"	75	27	G1/4"	27	4	ER25M	E25M
EM252675FL	ER25	1"	75	27	18	27	2 / 3	ER25M	E25M
EM252675IKFL	ER25	1"	75	27	G1/4"	27	2 / 4	ER25M	E25M
EM2526100FL	ER25	1"	100	27	14	27	2 / 3	ER25M	E25M
EM2526150WD	ER25	1"	150	27	14	27	3	ER25M	E25M
EM252890IKWD	ER25	28	90	17	M12x1,5	24	4	ER25M	E25M
EM2530150	ER25	30	150	14,5	19	27	3*	ER25M	E25M
EM2530150FL	ER25	30	150	14	18	27	2 / 3	ER25M	E25M
EM2530180	ER25	30	180	14	18	27	3*	ER25M	E25M
EM2530180FL	ER25	30	180	14	18	27	2 / 3	ER25M	E25M
EM253250WD	ER25	32	50	24	18	-	3	ER25M	E25M
EM253262WD	ER25	32	62	16	18	27	3	ER25M	E25M
EM253280IKWD	ER25	32	80	16	G1/4"	27	4	ER25M	E25M
EM2532180	ER25	32	179	16	18	27	3*	ER25M	E25M
EM2532180FL	ER25	32	180	16	18	27	2 / 3	ER25M	E25M

* = ohne Spannfläche - without flat

ER-Zangenspannfutter ER11

ER-Collet Holders ER11

Ausführungen:

Versions:

Vgl. auch S. 4 + 5

See also page 4 + 5



Bild 1 (WD)



Bild 2 (FL)

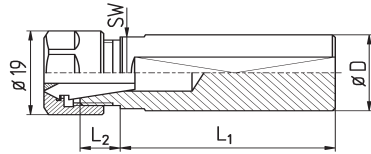

Bild 3 (B)



Bild 4 (IK)

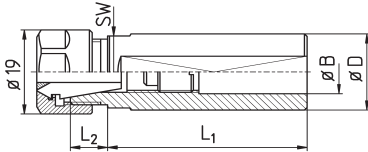

UM/ER11 = M14 x 0,75

Abbildungen können abweichen - catalog drawings may differ

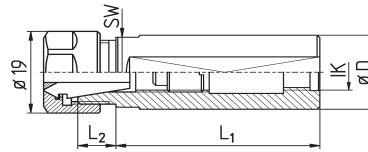
Bestell-Nr. order-no.	Zange collet	D	L ₁	L ₂	IK / B ic / B	SW	Bild picture	Mutter nut	Schlüssel spanner
EU110865	ER11	8	66	21	-	11	1*	UM/ER11	GS17
EU1110150	ER11	10	150	22	-	12	1*	UM/ER11	GS17
EU111370	ER11	1/2"	70	23	-	12	1*	UM/ER11	GS17
EU111428	ER11	14	28	10	7	12	3*	UM/ER11	GS17
EU111465	ER11	14	64	9	6	-	3*	UM/ER11	GS17
EU1118310	ER11	18	310	12	-	15	1*	UM/ER11	GS17
EU111930WD	ER11	3/4"	29	8	7	17	3	UM/ER11	GS17
EU111940IK	ER11	3/4"	38	10	7	17	4*	UM/ER11	GS17
EU111940IKWD	ER11	3/4"	38	10	7	17	4	UM/ER11	GS17
EU111950	ER11	3/4"	50	12	8	17	3*	UM/ER11	GS17
EU111955WD	ER11	3/4"	55	12	7	17	3	UM/ER11	GS17
EU111960WD	ER11	3/4"	60	12	9	17	3	UM/ER11	GS17
EU111970IKWD	ER11	3/4"	70	12	G1/8"	17	4	UM/ER11	GS17
EU1119125IK	ER11	3/4"	125	12	G1/8"	17	4*	UM/ER11	GS17
EU1119125IKWD	ER11	3/4"	125	12	G1/8"	17	4	UM/ER11	GS17
EU112030WD	ER11	20	30	11	7	17	3	UM/ER11	GS17
EU112050WD	ER11	20	50	12	8,5	17	3	UM/ER11	GS17
EU112060	ER11	20	60	12	8,5	17	3*	UM/ER11	GS17
EU112060WD	ER11	20	60	12	8,5	17	3	UM/ER11	GS17
EU112080WD	ER11	20	80	12	10,5	17	3	UM/ER11	GS17
EU1120100	ER11	20	100	12	11	17	3*	UM/ER11	GS17
EU1120100FL	ER11	20	100	12	11	17	2 / 3	UM/ER11	GS17
EU1120145IK	ER11	20	145	12	G1/8"	16	4*	UM/ER11	GS17
EU1120170	ER11	20	170	11	-	17	1*	UM/ER11	GS17
EU1120245	ER11	20	245	13	-	17	1*	UM/ER11	GS17
EU1120300	ER11	20	300	13	-	17	1*	UM/ER11	GS17
EU112270IK	ER11	22	70	13	G1/4"	19	4*	UM/ER11	GS17
EU112270IKFL	ER11	22	70	13	G1/4"	19	2 / 4	UM/ER11	GS17
EU112290IK	ER11	22	90	12	G1/4"	19	4*	UM/ER11	GS17
EU112290IKFL	ER11	22	90	12	G1/4"	19	2 / 4	UM/ER11	GS17
EU112290IKWD	ER11	22	90	12	G1/4"	19	4	UM/ER11	GS17
EU112570IK	ER11	25	70	12	G1/4"	22	4*	UM/ER11	GS17
EU112570WD	ER11	25	70	12	7	22	3	UM/ER11	GS17
EU112585	ER11	25	85	12	11	22	3*	UM/ER11	GS17
EU112585IK	ER11	25	85	12	G1/4"	22	4*	UM/ER11	GS17
EU112585WD	ER11	25	85	12	11	22	3	UM/ER11	GS17
EU112673WD	ER11	1"	73	12	10	22	3	UM/ER11	GS17
EU112675IKWD	ER11	1"	75	12	G1/4"	22	4	UM/ER11	GS17

* = ohne Spannfläche - without flat

ER-Zangenspannfutter ER16

ER-Collet Holders ER16

Ausführungen:

Versions:

Vgl. auch S. 4 + 5

See also page 4 + 5



Bild 1 (WD)



Bild 2 (FL)

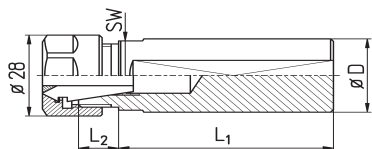

Bild 3 (B)

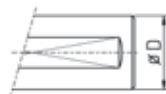

Bild 4 (IK)

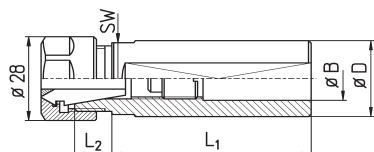

UM/ER16 = M22 x 1,5

Abbildungen können abweichen - catalog drawings may differ

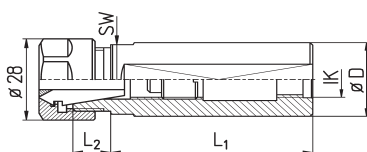
Bestell-Nr. order-no.	Zange collet	D	L ₁	L ₂	IK / B ic / B	SW	Bild picture	Mutter nut	Schlüssel spanner
EU161060	ER16	10	60	27	-	19	1*	UM/ER16	GS25
EU161240	ER16	12	40	25	6	19	3*	UM/ER16	GS25
EU1613100	ER16	1/2"	100	27	9	19	3*	UM/ER16	GS25
EU161460	ER16	14	60	27	8,5	19	3*	UM/ER16	GS25
EU161550	ER16	15	50	25	8,5	19	3*	UM/ER16	GS25
EU165860	ER16	5/8"	60	25	10	19	3*	UM/ER16	GS25
EU161660	ER16	16	60	25	10	19	3*	UM/ER16	GS25
EU161660FL	ER16	16	60	25	10	19	2 / 3	UM/ER16	GS25
EU161940IK	ER16	3/4"	39	15	G1/4"	17	4*	UM/ER16	GS25
EU161938WD	ER16	3/4"	38	25	11	19	3	UM/ER16	GS25
EU161945	ER16	3/4"	46	13	11,5	-	3*	UM/ER16	GS25
EU161950	ER16	3/4"	50	22	10	19	3*	UM/ER16	GS25
EU161950FL	ER16	3/4"	50	25	11	19	2 / 3	UM/ER16	GS25
EU161955	ER16	3/4"	55	15	11	17	3*	UM/ER16	GS25
EU161950WD	ER16	3/4"	50	15	11	17	3	UM/ER16	GS25
EU1619100	ER16	3/4"	100	25	11	19	3*	UM/ER16	GS25
EU162050	ER16	20	50	22	11	19	3*	UM/ER16	GS25
EU162050FL	ER16	20	50	22	11	19	2 / 3	UM/ER16	GS25
EU162075WD	ER16	20	73	12	11	17	3	UM/ER16	GS25
EU1620100FL	ER16	20	100	24	11	19	2 / 3	UM/ER16	GS25
EU1620100	ER16	20	100	14	12	19	3*	UM/ER16	GS25
EU162235SO	ER16	22	35	13	G 1/4"	19	4	UM/ER16	GS25
EU162255IKWD	ER16	22	54	12	G1/4"	19	4	UM/ER16	GS25
EU1622105OSWD	ER16	22	105	12	10	19	4	UM/ER16	GS25
EU1622105WD	ER16	22	103	12	10	19	3	UM/ER16	GS25
EU162560IKFL	ER16	25	60	16	G1/4"	22	2 / 4	UM/ER16	GS25
EU162575WD	ER16	25	75	16	12	22	3	UM/ER16	GS25
EU1625100FL	ER16	25	100	16	11	22	2 / 3	UM/ER16	GS25
EU1625125IK	ER16	25	125	16	G1/4"	22	4*	UM/ER16	GS25
EU1625125IKWD	ER16	25	125	16	G1/4"	22	4	UM/ER16	GS25
EU1625150IK	ER16	25	150	16	G1/4"	22	4*	UM/ER16	GS25
EU1625150IKWD	ER16	25	150	16	G1/4"	22	4	UM/ER16	GS25
EU1625220	ER16	25	220	23	-	19	1*	UM/ER16	GS25
EU1625220WD	ER16	25	220	23	-	19	1	UM/ER16	GS25

* = ohne Spannfläche - without flat

Bestell-Nr. order-no.	Zange collet	D	L ₁	L ₂	IK / B ic / B	SW	Bild picture	Mutter nut	Schlüssel spanner
EU162638	ER16	1"	38	16	12	22	3*	UM/ER16	GS25
EU162638WD	ER16	1"	38	16	12	22	3	UM/ER16	GS25
EU162638FL	ER16	1"	38	16	12	22	2 / 3	UM/ER16	GS25
EU162660	ER16	1"	60	16	12	22	3*	UM/ER16	GS25
EU162660IKWD	ER16	1"	60	16	G1/4"	22	4	UM/ER16	GS25
EU162660FL	ER16	1"	58	16	12	22	2 / 3	UM/ER16	GS25
EU162675	ER16	1"	75	16	12	22	3*	UM/ER16	GS25
EU162675IKWD	ER16	1"	75	16	G1/4"	22	4	UM/ER16	GS25
EU1626100	ER16	1"	100	16	12	22	3*	UM/ER16	GS25
EU1626100FL	ER16	1"	100	16	11	22	2 / 3	UM/ER16	GS25
EU1626124WD	ER16	1"	124	16	11	22	3	UM/ER16	GS25
EU163220WD	ER16	32	20	16	10	-	3	UM/ER16	GS25
EU163240WD	ER16	32	40	16	12	-	3	UM/ER16	GS25
EU163260IK	ER16	32	60	16	G1/4"	27	4*	UM/ER16	GS25
EU163260IKFL	ER16	32	60	16	G1/4"	27	2 / 4	UM/ER16	GS25
EU163260FL	ER16	32	60	16	12	27	2 / 3	UM/ER16	GS25
EU164060FL	ER16	40	60	25	11	-	2 / 3	UM/ER16	GS25

* = ohne Spannfläche - without flat

ER-Zangenspannfutter ER20

ER-Collet Holders ER20

Ausführungen:

Versions:

Vgl. auch S. 4 + 5

See also page 4 + 5



Bild 1 (WD)



Bild 2 (FL)

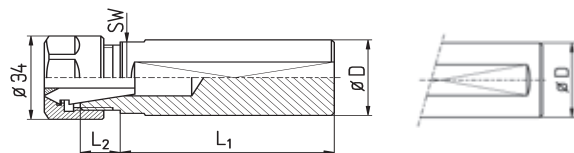

Bild 3 (B)

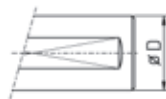

Bild 4 (IK)

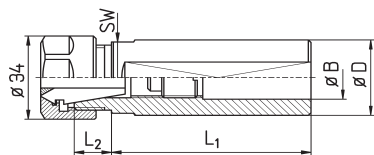

UM/ER20 = M25 x 1,5

Abbildungen können abweichen - catalog drawings may differ

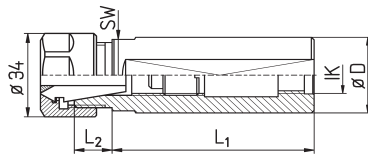
Bestell-Nr. order-no.	Zange collet	D	L ₁	L ₂	IK / B ic / B	SW	Bild picture	Mutter nut	Schlüssel spanner
EU2013100	ER20	1/2"	100	35	-	-	1*	UM/ER20	GS30
EU2058100	ER20	5/8"	100	35	-	-	1*	UM/ER20	GS30
EU201936	ER20	3/4"	36	17	13	-	3*	UM/ER20	GS30
EU201938	ER20	3/4"	38	16	13	-	3*	UM/ER20	GS30
EU201950	ER20	3/4"	50	22	13	22	3*	UM/ER20	GS30
EU201950K	ER20	3/4"	50	15	14	-	3*	UM/ER20	GS30
EU202030	ER20	20	30	25	13	22	3*	UM/ER20	GS30
EU202050	ER20	20	50	25	14	22	3*	UM/ER20	GS30
EU202050KFL	ER20	20	50	17	14	-	2 / 3	UM/ER20	GS30
EU202055IK	ER20	20	54	22	G1/4"	22	3*	UM/ER20	GS30
EU202060FL	ER20	20	60	25	13	22	2 / 3	UM/ER20	GS30
EU202060	ER20	20	60	22	13	22	3*	UM/ER20	GS30
EU202085IKWD	ER20	20	85	25	M12 x 1,5	22	4	UM/ER20	GS30
EU2020100	ER20	20	100	25	13	22	3*	UM/ER20	GS30
EU2020100FL	ER20	20	100	25	13	22	2 / 3	UM/ER20	GS30
EU2022100WD	ER20	22	104	13	12	19	3	UM/ER20	GS30
EU2025100IK	ER20	25	102	14	G1/4"	22	4*	UM/ER20	GS30
EU2025100IKWD	ER20	25	102	14	G1/4"	22	4	UM/ER20	GS30
EU2025145IKFL	ER20	25	143	13	G1/4"	22	2 / 4	UM/ER20	GS30
EU202638	ER20	1"	38	16	16	22	3*	UM/ER20	GS30
EU202638FL	ER20	1"	38	16	13	22	2 / 3	UM/ER20	GS30
EU202685WD	ER20	1"	83	14	13	22	3	UM/ER20	GS30
EU2026100IK	ER20	1"	100	16	G1/4"	22	4*	UM/ER20	GS30

* = ohne Spannfläche - without flat

ER-Zangenspannfutter ER25

ER-Collet Holders ER25

Ausführungen:

Versions:

Vgl. auch S. 4 + 5

See also page 4 + 5



Bild 1 (WD)

Bild 2 (FL)

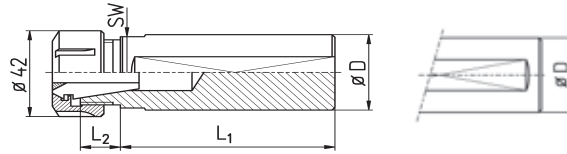

Bild 3 (B)

Bild 4 (IK)

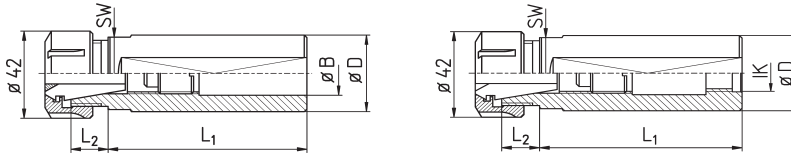
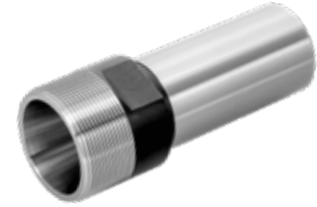

UM/ER25 = M32 x 1,5

Abbildungen können abweichen - catalog drawings may differ

Bestell-Nr. order-no.	Zange collet	D	L ₁	L ₂	IK / B ic / B	SW	Bild picture	Mutter nut	Schlüssel spanner
EU2516100	ER25	16	100	36	-	27	1*	UM/ER25	E25
EU2516100FL	ER25	16	100	36	-	27	1 / 2	UM/ER25	E25
EU251950	ER25	3/4"	50	33	13	27	3*	UM/ER25	E25
EU251950FL	ER25	3/4"	50	33	13	27	2 / 3	UM/ER25	E25
EU2519100	ER25	3/4"	100	33	13	27	3*	UM/ER25	E25
EU252050	ER25	20	50	33	14	27	3*	UM/ER25	E25
EU252050oB	ER25	20	50	33	-	27	1*	UM/ER25	E25
EU252050FL	ER25	20	50	33	14	27	2 / 3	UM/ER25	E25
EU2520100	ER25	20	100	33	11	27	3*	UM/ER25	E25
EU2520100FL	ER25	20	100	33	11	27	2 / 3	UM/ER25	E25
EU252550	ER25	25	50	27	18	27	3*	UM/ER25	E25
EU252550FL	ER25	25	50	27	18	27	2 / 3	UM/ER25	E25
EU252550K	ER25	25	50	20	17	-	3*	UM/ER25	E25
EU2525100	ER25	25	100	27	14	27	3*	UM/ER25	E25
EU2525100WD	ER25	25	100	27	14	27	3	UM/ER25	E25
EU2525150IK	ER25	25	150	27	G1/4"	27	4*	UM/ER25	E25
EU2525150IKWD	ER25	25	150	27	G1/4"	27	4	UM/ER25	E25
EU2525150FL	ER25	25	150	27	14	27	2 / 3	UM/ER25	E25
EU252650	ER25	1"	50	27	18	27	3*	UM/ER25	E25
EU252660WD	ER25	1"	60	27	18	27	3	UM/ER25	E25
EU2526100	ER25	1"	100	27	14	27	3*	UM/ER25	E25
EU2526100FL	ER25	1"	100	27	14	27	2 / 3	UM/ER25	E25
EU253060	ER25	30	60	27	18	27	3*	UM/ER25	E25
EU253060FL	ER25	30	60	27	16	27	2 / 3	UM/ER25	E25
EU253185	ER25	1 1/4"	85	15	18	27	3*	UM/ER25	E25
EU2531180	ER25	1 1/4"	180	14	18	27	3*	UM/ER25	E25
EU2531180FL	ER25	1 1/4"	180	14	18	27	2 / 3	UM/ER25	E25
EU253275	ER25	32	75	15	18	-	3*	UM/ER25	E25
EU2532110	ER25	32	110	14	17	27	3*	UM/ER25	E25
EU2532115FL	ER25	32	115	14	18	27	2 / 3	UM/ER25	E25
EU2532180	ER25	32	180	14	18	27	3*	UM/ER25	E25
EU2532180FL	ER25	32	180	14	18	27	2 / 3	UM/ER25	E25
EU254080	ER25	40	80	18	19	36	3*	UM/ER25	E25
EU255082WD	ER25	50	82	18	-	-	1	UM/ER25	E25

* = ohne Spannfläche - without flat

ER-Zangenspannfutter ER32

ER-Collet Holders ER32

Ausführungen:

Versions:

Vgl. auch S. 4 + 5

See also page 4 + 5



Bild 1 (WD)



Bild 2 (FL)

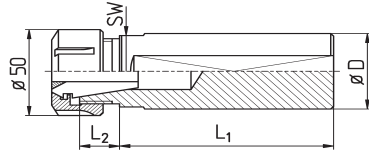

Bild 3 (B)

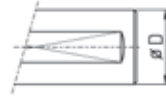

Bild 4 (IK)

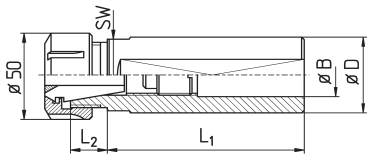

UM/ER32 = M40 x 1,5

Abbildungen können abweichen - catalog drawings may differ

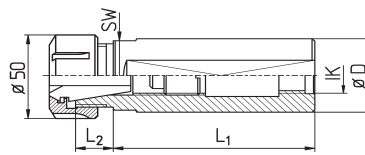
Bestell-Nr. order-no.	Zange collet	D	L ₁	L ₂	IK / B ic / B	SW	Bild picture	Mutter nut	Schlüssel spanner
EU321950	ER32	3/4"	50	40	13	36	3*	UM/ER32	E32
EU3219100	ER32	3/4"	100	40	13	36	3*	UM/ER32	E32
EU322050	ER32	20	50	40	13	36	3*	UM/ER32	E32
EU322050FL	ER32	20	50	40	13	36	2 / 3	UM/ER32	E32
EU3220100	ER32	20	100	40	13	36	3*	UM/ER32	E32
EU3220100FL	ER32	20	100	40	13	36	2 / 3	UM/ER32	E32
EU322550	ER32	25	50	40	18	36	3*	UM/ER32	E32
EU322550FL	ER32	25	50	40	18	36	2 / 3	UM/ER32	E32
EU3225100	ER32	25	100	40	17	36	3*	UM/ER32	E32
EU3225100FL	ER32	25	100	40	17	36	2 / 3	UM/ER32	E32
EU322650	ER32	1"	50	40	18	36	3*	UM/ER32	E32
EU3226100	ER32	1"	100	40	16	36	3*	UM/ER32	E32
EU323060WD	ER32	30	60	27	18	36	3	UM/ER32	E32
EU323065FL	ER32	30	64	25	21	-	2 / 3	UM/ER32	E32
EU323160	ER32	1 1/4"	60	27	20	36	3*	UM/ER32	E32
EU323260	ER32	32	60	27	22	36	3*	UM/ER32	E32
EU3232100FL	ER32	32	100	27	20	36	2 / 3	UM/ER32	E32
EU324070FL	ER32	40	70	17	23	36	2 / 3	UM/ER32	E32
EU324080	ER32	40	84	16	23	36	3*	UM/ER32	E32
EU3240130	ER32	40	130	17	23	36	3*	UM/ER32	E32
EU3240130FL	ER32	40	131	15	23	36	2 / 3	UM/ER32	E32
EU3240150	ER32	40	153	17	25	36	3*	UM/ER32	E32
EU3240210	ER32	40	210	19	25	-	3*	UM/ER32	E32

* = ohne Spannfläche - without flat

ER-Zangenspannfutter ER40 + ER50

ER-Collet Holders ER40 + ER50

Ausführungen:

Versions:

Vgl. auch S. 4 + 5

See also page 4 + 5



Bild 1 (WD)



Bild 2 (FL)

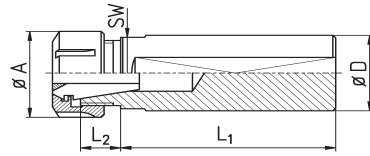

Bild 3 (B)

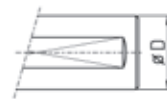

Bild 4 (IK)

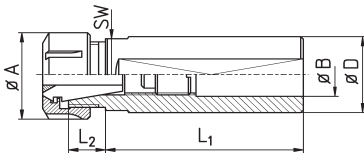

UM/ER40 = M50 x 1,5

Abbildungen können abweichen - catalog drawings may differ

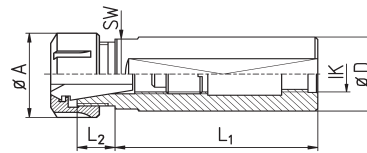
Bestell-Nr. order-no.	Zange collet	D	L ₁	L ₂	A	IK / B ic / B	SW	Bild picture	Mutter nut	Schlüssel spanner
EU401960	ER40	3/4"	60	43	63	11	46	3*	UM/ER40	E40
EU402060	ER40	20	60	43	63	12	46	3*	UM/ER40	E40
EU402550	ER40	25	50	43	63	17	46	3*	UM/ER40	E40
EU402550FL	ER40	25	50	45	63	18	46	2 / 3	UM/ER40	E40
EU402650	ER40	1"	50	45	63	18	46	3*	UM/ER40	E40
EU403160	ER40	1 1/4"	60	43	63	23	46	3*	UM/ER40	E40
EU403260	ER40	32	60	43	63	22	46	3*	UM/ER40	E40
EU403275	ER40	32	75	43	63	24	41	3*	UM/ER40	E40
EU403680	ER40	36	80	43	63	23	46	3*	UM/ER40	E40
EU404080	ER40	40	80	44	63	28	46	3*	UM/ER40	E40
EU404080FL	ER40	40	80	44	63	28	46	2 / 3	UM/ER40	E40
EU4040200	ER40	40	200	44	63	26	46	3*	UM/ER40	E40
EU4040200TR	ER40	40	200	26	63	25	36	3*	UM/ER40	E40
EU4045100WD	ER40	45	100	20	63	31,5	-	3	UM/ER40	E40
EU4050160	ER40	50	160	18	63	25	46	3*	UM/ER40	E40
EU4050195	ER40	50	195	27	63	25	-	3*	UM/ER40	E40

* = ohne Spannfläche - without flat

Pinolenanschlätze für Bohrpinoles, Bohrverlängerungen

Collet Holder Stops for Pre Setting



Bild 1



Bild 2

Bestell-Nr. order-no.	B	A	C	Bild picture
EM-PA16	16	23,5	7	1
EM-PA19	3/4"	23	8	1
EM-PA20	20	23	8	1
EM-PA22	22	25	8	1
EM-PA22B	22	34	8	2
EM-PA25	25	30	8	1
EM-PA26	1"	30	8	1
EM-PA32	32	40	8	1

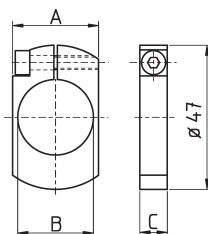
**ER-Zangenspannfutter
mit seitlichem und rückseitigem
Kühlmittelanschluss**

**ER-Collet Holders
with Inner Coolant,
Side and Rear**

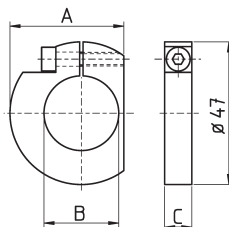
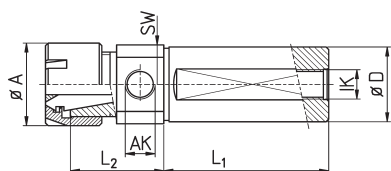

ERC16M = M19 x 1



ERC20M = M24 x 1



ERC25M = M30 x 1

Lieferung incl. Mutter für Dichtscheiben - supplied with nut for sealing disks

Bestell-Nr. order-no.	Zange collet	D	L ₁	L ₂	A	AK	IK	Mutter nut	Schlüssel spanner
EM161650AK1WD	ER16	16	50	30	22	G1/8"	M8x1	ERC16M	E16M
EM1618310AK1	ER16	18	310	35	22	G1/8"	-	ERC16M	E16M
EM161930AK1WD	ER16	3/4"	30	30	22	G1/8"	G1/8"	ERC16M	E16M
EM161950AK1WD	ER16	3/4"	50	30	22	G1/8"	G1/8"	ERC16M	E16M
EM161960AK0WD	ER16	3/4"	60	30	22	M12x1,5	G1/8"	ERC16M	E16M
EM161960AK1WD	ER16	3/4"	60	30	22	G1/8"	G1/8"	ERC16M	E16M
EM161960AK1	ER16	3/4"	60	27	22	G1/8"	G1/8"	ERC16M	E16M
EM161970AK0WD	ER16	3/4"	70	30	22	M12x1,5	G1/8"	ERC16M	E16M
EM161970AK1WD	ER16	3/4"	70	27	22	G1/8"	G1/8"	ERC16M	E16M
EM161970AK3WD	ER16	3/4"	70	30	22	M10x1	G1/8"	ERC16M	E16M
EM1619100AK1WD	ER16	3/4"	100	27	22	G1/8"	G1/8"	ERC16M	E16M
EM162050AK0WD	ER16	20	50	30	22	M12x1,5	G1/8"	ERC16M	E16M
EM162050AK1WD	ER16	20	50	27	22	G1/8"	G1/8"	ERC16M	E16M
EM162070AK0WD	ER16	20	70	30	22	M12x1,5	G1/8"	ERC16M	E16M
EM162070AK1WD	ER16	20	70	27	22	G1/8"	G1/8"	ERC16M	E16M
EM1620310AK1	ER16	20	310	35	22	G1/8"	--	ERC16M	E16M
EM162250AK0WD	ER16	22	50	30	22	M12x1,5	M12x1,5	ERC16M	E16M
EM162250AK1WD	ER16	22	50	27	22	G1/8"	G1/8"	ERC16M	E16M
EM162250AK3WD	ER16	22	50	30	22	M10x1	M12x1,75	ERC16M	E16M
EM162270AK0WD	ER16	22	70	30	22	M12x1,5	M12x1,75	ERC16M	E16M
EM162270AK1WD	ER16	22	70	27	22	G1/8"	G1/8"	ERC16M	E16M
EM162270AK2WD	ER16	22	70	27	22	M8x1	G1/8"	ERC16M	E16M
EM162270AK3WD	ER16	22	70	30	22	M10x1	M12x1,75	ERC16M	E16M
EM162550AK0WD	ER16	25	50	30	22	M12x1,5	G1/4"	ERC16M	E16M
EM162550AK1WD	ER16	25	50	27	22	G1/8"	G1/4"	ERC16M	E16M
EM162550AK2WD	ER16	25	50	26	22	M8x1	G1/4"	ERC16M	E16M
EM162570AK0WD	ER16	25	70	32	22	M12x1,5	G1/4"	ERC16M	E16M
EM162570AK1WD	ER16	25	70	30	22	G1/8"	G1/4"	ERC16M	E16M

Bestell-Nr. order-no.	Zange collet	D	L ₁	L ₂	A	AK	IK	Mutter nut	Schlüssel spanner
EM162650AK0WD	ER16	1"	50	30	22	M12x1,5	G1/4"	ERC16M	E16M
EM162650AK1WD	ER16	1"	50	30	22	G1/8"	G1/4"	ERC16M	E16M
EM162660AK0WD	ER16	1"	60	30	22	M12x1,5	M12x1,75	ERC16M	E16M
EM162660AK1WD	ER16	1"	60	30	22	G1/8"	M12x1,75	ERC16M	E16M
EM162670AK0WD	ER16	1"	70	30	22	M12x1,5	G1/8"	ERC16M	E16M
EM162670AK1WD	ER16	1"	70	27	22	G1/8"	G1/8"	ERC16M	E16M
EM162670AK2WD	ER16	1"	70	30	22	M8x1	G1/4"	ERC16M	E16M
EM202250AK0WD	ER20	22	50	34	28	M12x1,5	G1/8"	ERC20M	E20M
EM2025150AK1WD	ER20	25	150	34	28	G1/8"	G1/4"	ERC20M	E20M
EM202550AK1WD	ER20	25	50	34	28	G1/8"	G1/4"	ERC20M	E20M
EM202550AK2WD	ER20	25	50	34	28	M8x1	G1/4"	ERC20M	E20M
EM202650AK1WD	ER20	1"	50	34	28	G1/8"	G1/4"	ERC20M	E20M
EM202650AK2WD	ER20	1"	50	34	28	M8x1	G1/4"	ERC20M	E20M
EM2525137AK1WD	ER25	25	137	40	35	G1/8"	M12x1,5	ERC25M	E25M

ER-Zangenspannfutter mit seitlichem Kühlmittelanschluss

ER-Collet Holders with Side Coolant Inlet

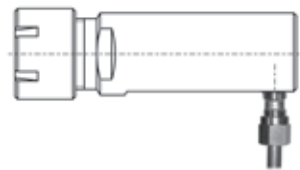
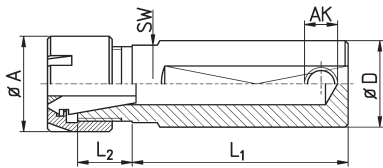

ERC16M = M19 x 1

Bestell-Nr. order-no.	Zange collet	D	L ₁	L ₂	A	SW	AK ic	Mutter nut	Schlüssel spanner
EM162260WDAKS1	ER 16	22	60	16	22	19	G1/8"	ERC16M	E16M
EM162270WDAKS1	ER 16	22	70	16	22	19	G1/8"	ERC16M	E16M
EM162280WDAKS1	ER 16	22	80	16	22	19	G1/8"	ERC16M	E16M

CNC Zangenspannfutter
mit Klemmfläche - für innere Kühlmittelzufuhr

CNC Collet Holders
with Clamping Flat - Inner Coolant

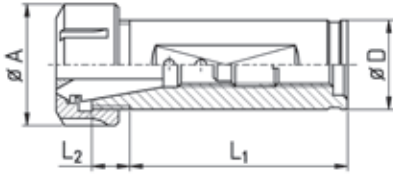

Bestell-Nr. order-no.	Zange collet	D	A	L ₁	L ₂	Mutter nut	Schlüssel spanner
EU253275FL-CNC	ER 25	32	42	75	14	UM/ER 25	E25
EU254080FL-CNC	ER 25	40	42	80	18	UM/ER 25	E25
EU323260FL-CNC	ER 32	32	50	60	27	UM/ER 32	E32
EU324080FL-CNC	ER 32	40	50	80	18	UM/ER 32	E32
EU3245100FL-CNC	ER 32	45	50	100	20	UM/ER 32	E32
EU3250120FL-CNC	ER 32	50	50	120	20	UM/ER 32	E32
EU403260FL-CNC	ER 40	32	63	60	43	UM/ER 40	E40
EU404075FL-CNC	ER 40	40	63	75	32	UM/ER 40	E40
EU4045100FL-CNC	ER 40	45	63	100	20	UM/ER 40	E40
EU4050120FL-CNC	ER 40	50	63	120	18	UM/ER 40	E40



UM/ER25 = M32 x 1,5

UM/ER32 = M40 x 1,5

UM/ER40 = M50 x 1,5

ER-Zangenspannfutter
für STAR / MAIER-Maschinen / Rückseite

ER-Collet Holders
for STAR / MAIER-Machines / Backworking

Bild 1



Bild 2



ER11M = M13 x 0,75

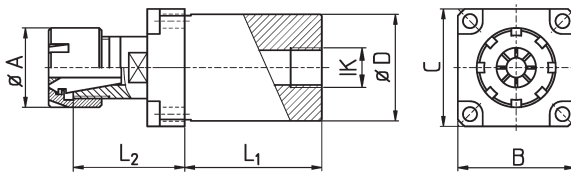
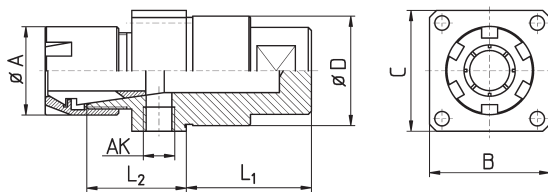

ER16M = M19 x 1



ER20M = M24 x 1



ER25M = M30 x 1

Bestell-Nr. order-no.	Zange collet	D	L ₁	L ₂	A	B	C	AK IK	Bild picture	Mutter nut	Maschinen-Typ machine type
EM1130MM	ER11	30	45	29	16	32	39,5	G1/8"	1	ER11M	MAIER
EM1630MM	ER16	30	45	26	22	31,5	39,5	G1/8"	1	ER16M	
EM1634MK	ER16	34	19,5	26	22	37,5	37,5	G1/4"	1	ER16M	
EM1634MM	ER16	34	44	26	22	37,5	37,5	M14x1,5	1	ER16M	
EM1634MS	ER16	34	19	22	22	37,5	37,5	M11x1	1	ER16M	
EM2034MK	ER20	34	19,5	25	28	37,5	37,5	G1/4"	1	ER20M	MAIER
EM2034MK-AK1	ER20	34	19,5	34	28	37,5	37,5	G1/8"	2	ER20M	
EM2034MM	ER20	34	44	25	28	37,5	37,5	G1/4"	1	ER20M	STAR ECAS32T ST38 SV38R
EM2534MK	ER25	34	19,5	5	35	37,5	37,5	G1/4"	1	ER25M	
EM2534MK-AK1	ER25	34	19,5	42	35	37,5	37,5	G1/8"	2	ER25M	
EM2534MM	ER25	34	44	28	35	37,5	37,5	G1/4"	1	ER25M	
EM2034SV38R-AK1	ER20	34	39	31	28	37,5	37,5	G1/8"	2	ERC20M	
EM2034SV38R-AK2	ER20	34	39	31	28	37,5	37,5	M8x1	2	ERC20M	

ER-Zangenspannfutter für HANWHA / TORNOS

ER-Collet Holders for HANWHA / TORNOS

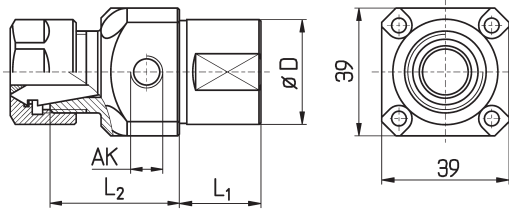

Bestell-Nr. order-no.	Zange collet	D	L ₁	L ₂	Mutter nut	Maschinen-Typ machine type
EU1632HA32-AK2	ER16	32	25	23,5	ERC16	HANWHA XD20 / 32H / 32I
EU1633HA20-AK1	ER16	33	37	35	ERC16	
EM2033HA20-AK1	ER20	33	37	35	ERC20M	
EU1632HA32-AK1	ER16	32	25	22	ERC16	HANWHA STL38
EU2032HA32-AK1	ER20	32	25	27	ERC20	
EU2032HA32-AK2	ER20	32	25	27	ERC20	
EM2532HA32-AK1	ER25	32	25	23,5	ERC25M	
EM2532HA32-AK2	ER25	32	25	23,5	ERC25M	
EM1628CT20-AK1	ER16	28	36	36	ERC16	TORNOS CT20
EU1628CT20-AK1	ER16	28	36	36	ERC16	
EM2028CT20-AK1	ER20	28	36	36	ERC20M	



ERC16 = M22 x 1,5



ERC20M = M24 x 1



ERC20 = M25 x 1,5



ERC25M = M30 x 1

ER-Zangenspannfutter für Doppelspindel-Maschinen

ER-Collet Holders for Double Spindle Machines



Bild 1



Bild 2

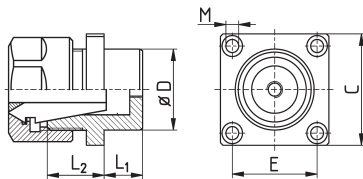

UM/ER25 = M32 x 1,5

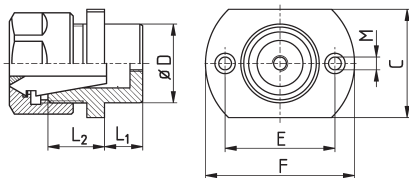

UM/ER32 = M40 x 1,5



UM/ER40 = M50 x 1,5

Bestell-Nr. order-no.	Zange collet	D	L ₁	L ₂	E	F	C	M	Bild picture	Mutter nut
EU253220-HE	ER25	32	20	18	32	55	41	4,5	1	UM/ER25
EU254020-HE	ER25	40	19,5	22	43	76	55	6,6	2	UM/ER25
EU323220-HE	ER32	32	20	23,5	50	60	41	4,5	2	UM/ER32
EU324020-HE	ER32	40	19,5	27	43	76	55	6,6	1	UM/ER32
EU404020-HE	ER40	40	19,5	30	43	76	55	6,6	1	UM/ER40

ER-Zangenspannfutter
für STAR-Maschinen / Rückseitenbearbeitung

ER-Collet Holders
for STAR-Machines / Backworking



Bild 1



Bild 2

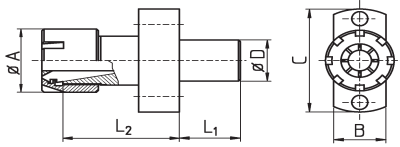

Bild 3

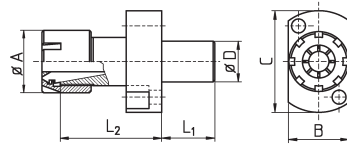

Bild 4

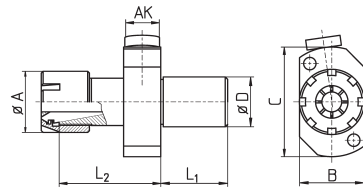

Bild 5

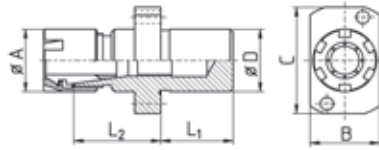

Bild 6



Bild 7

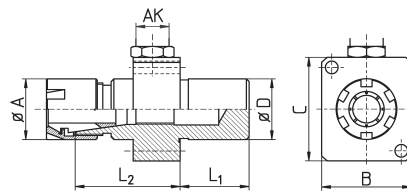

Bild 8

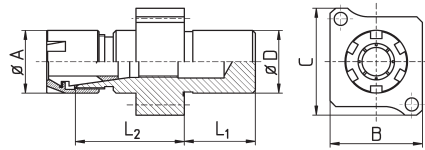

Bild 9

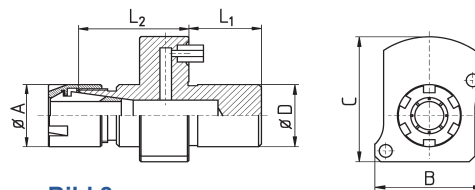

Bestell-Nr. order-no.	Zange collet	D	L ₁	L ₂	A	B	C	AK	Bild picture	Mutter nut	Maschinen-Typ machine type
EM1116SRJ	ER11	16	10	45	16	17	41	--	1	ER11M	SR10J (Pos T21 + T23)
EM1116SR	ER11	16	20	17	16	24	40	--	2	ER11M	SR16 ; SR20
EU1116SR	ER11	16	20	17	20	24	40	--	2		
EM1616SRMS	ER16	16	20	17	22	24	40	--	2	ER16M	
EM1616SROS*	ER16	16	20	17	22	24	40	--	2	ER16M	
EM1116SRR	ER11	16	10	18	16	17	41	--	2	ER11M	SR16R
EM1122SRR	ER11	22	25	46	16	28	49	--	2	ER11M	SR10J (Pos T22+ T24) ; SB12 / 20R ; SB16 / 20 ; SR20J / JN ; SR32J / JN ; SR20 R / II / III ; SV20R ; SW12R11 ; ECAS12/20 SR20RIV (Pos T21 - T24 verbaut / overlaps T25 - T28)
EM1622SRR	ER16	22	25	30	22	28	49	--	2	ER16M	
EM1622SRR-L	ER16	22	25	45	22	28	49	--	2	ER16M	
EM1622SRR-AK1	ER16	22	25	29	22	28	49	G1/8"	3	ERC16M	
EM1622SRR-AK2	ER16	22	25	29	22	28	49	M8x1	3	ERC16M	
EM1622SRR-c	ER16	22	25	21	22	28	49	--	2	ER16M	
EM2022SRR	ER20	22	25	27	28	28	49	--	2	ER20M	
EM2022SRR-AK1	ER20	22	25	30	28	28	49	G1/8"	3	ERC20M	
EM2022SRR-AK2	ER20	22	25	30	28	28	49	M8x1	3	ERC20M	
EM1622SW	ER16	22	25	38	22	32,5	37,5	--	5	ER16M	
EM1622SW-OS*	ER16	22	25	40	22	32,5	37,5	--	5*	ER16M	
EM1622SW-AK1	ER16	22	25	40	22	32,5	37,5	G1/8"	6	ERC16M	
EM1622SW-AK2	ER16	22	25	38	22	32,5	37,5	M8x1	6	ERC16M	
EM1622SW2-OS*	ER16	22	25	40	22	32,5	37,5	--	7*	ER16M	
EM2022SW	ER20	22	25	32	28	32,5	37,5	--	5	ER20M	
EM2022SW-AK1	ER20	22	25	32	28	32,5	37,5	G1/8"	6	ERC20M	
EM2022SW2-OS*	ER20	22	25	27	28	32,5	37,5	--	7*	ER20M	
EM2022SW-AK1	ER20	22	25	32	28	32,5	37,5	G1/8"	6	ERC20M	
EM1622SWS	ER16	22	25	31	22	24	37,5	--	4	ER16M	SW20 (Pos T24 + T28)
EM2022SR	ER20	22	25	28	28	38	48	--	2	ER20M	SR32 ; SR32J
EM1622SWIK	ER16	22	25	35	22	37,5	44	--	8	ERC16M	SR38 ; SR32J11
EM2022SWIK	ER20	22	25	33	28	37,5	44	--	8	ERC20M	
EU2522SWIK	ER25	22	25	33	42	49	47	--	9	ERC25	

* Ohne Innengewinde für Stellschraube

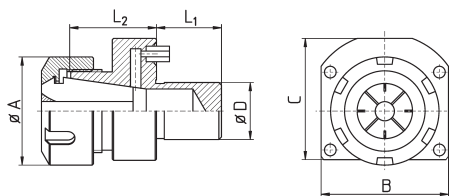
* Without thread for backstop screw



ER11M = M13 x 0,75



ER16M = M19 x 1



ERC16M = M19 x 1



ER20M = M24 x 1



ERC20M = M24 x 1



ERC25M = M32 x 1,5

ER-Zangenspannfutter mit B-Kegelaufnahme für Bohrmaschinen

ER-Collet Holders with B-Cone

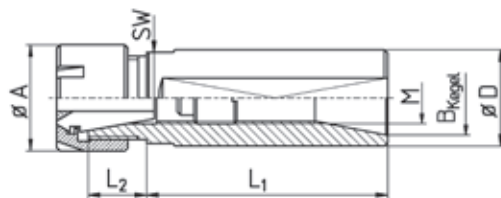

Bestell-Nr. order-no.	Typ / B-Kegel type / B-cone	Zange collet	D	L ₁	L ₂	A	M	Mutter nut	Schlüssel spanner
EM11SB10	ER11M / B10	ER 11	16	40	12	16	M8	ER11M	E11M
EM11LB10	ER11M / B10	ER 11	16	54	12	16	M8	ER11M	E11M
EM11SB12	ER11M / B12	ER 11	16	40	12	16	M8	ER11M	E11M
EM11LB12	ER11M / B12	ER 11	16	60	12	16	M8	ER11M	E11M
EM16SB10	ER16M / B10	ER 16	22	33	16	22	-	ER16M	E16M
EM16LB10	ER16M / B10	ER 16	22	45	16	22	M10	ER16M	E16M
EM16SB12	ER16M / B12	ER 16	22	33	16	22	-	ER16M	E16M
EM16LB12S	ER16M / B12	ER 16	20	43	16	22	M10	ER16M	E16M
EM16LB12	ER16M / B12	ER 16	22	45	16	22	M10	ER16M	E16M
EM16SB16	ER16M / B16	ER 16	22	33	15	22	-	ER16M	E16M
EU16LB12	ER16 / B12	ER 16	22	54	14	28	M10	UM/ER16	GS25
EM16LB16	ER16M / B16	ER 16	22	54	14	22	M10	ER16M	E16M
EU16SB16	ER16 / B16	ER 16	22	35	12	28	-	UM/ER16	GS25
EU16LB16	ER16 / B16	ER 16	22	53	15	28	M10	UM/ER16	GS25
EM20B12	ER20M / B12	ER 20	25	50	16	28	M14	ER20M	E20M
EM20B16	ER20M / B16	ER 20	25	50	16	28	M14	ER20M	E20M
EU20B16WD	ER20 / B16	ER 20	25	50	16	34	M14	UM/ER20	GS30
EM20B18	ER20M / B18	ER 20	25	50	16	28	M14	ER20M	E20M
EU25B16	ER25 / B16	ER 25	32	46	14	42	-	UM/ER25	E25
EU32B22	ER32 / B22	ER 32	40	55	16	50	M20	UM/ER32	E32

Auch mit JACOBS-Kegel lieferbar

Also available with JACOBS-cone



ER11M = M13 x 0,75



ER16M = M19 x 1



UM/ER16 = M22 x 1,5



ER20M = M24 x 1



UM/ER25 = M32 x 1,5



UM/ER32 = M40 x 1,5

ER-Zangenspannfutter
mit Anschlagbund; für Revolvermaschinen
und INDEX MS25

ER-Collet Holders
with Stop Flange; for Revolving Machines
and INDEX MS25

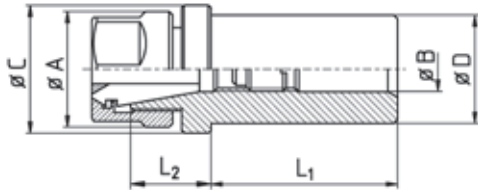

Bestell-Nr. order-no.	Zange collet	D	L ₁	L ₂	A	C	B	Mutter nut	Schlüssel spanner
EB110820	ER11	8	20	18,5	16	16	-	ER11M	E11M
EB111015	ER11	10	15	15	16	20	-	ER11M	E11M
EB111220	ER11	12	20	19	16	16	-	ER11M	E11M
EB111621WD	ER11	16	21	22	16	22	7	ER11M	E11M
EB160820	ER16	8	20	24	28	19	-	UM/ER16	GS25
EB161220	ER16	12	20	24	28	19	-	UM/ER16	GS25
EB162546	ER16	25	46	22	28	28	11	UM/ER16	GS25
EB162546FL	ER16	25	46	22	28	30	11	UM/ER16	GS25
EB162646	ER16	1"	46	21	28	28	11	UM/ER16	GS25
EB203250WD	ER20	32	50	34	34	34	15	UM/ER20	GS30
EB202565-HE	ER20	25	65	21	34	32	8	UM/ER20	GS30
EB252546	ER25	25	46	21	42	42	18	UM/ER25	E25
EB252546FL	ER25	25	46	21	42	40	18	UM/ER25	E25
EB252565-HE	ER25	25	65	23	42	32	8	UM/ER25	E25
EB252646K	ER25	1"	46	21	42	42	18	UM/ER25	E25
EB253238-HE	ER25	32	38	18	42	38	8	UM/ER25	E25
EB253265-HE	ER25	32	65	23	42	39	8	UM/ER25	E25
EB255082WD	ER25	50	82	23	42	59	7	UM/ER25	E25
EB322565WD-HE	ER32	25	65	41	50	40	7	UM/ER32	E32
EB324038-HE	ER32	40	38	23	50	49	8	UM/ER32	E32
EB325082WD	ER32	50	82	29	50	59	7	UM/ER32	E32
EB404065-HE	ER40	40	65	30	63	50	10	UM/ER40	E40



ER11M = M13 x 0,75



UM/ER16 = M22 x 1,5



UM/ER20 = M25 x 1,5



UM/ER25 = M32 x 1,5



UM/ER32 = M40 x 1,5



UM/ER40 = M50 x 1,5

VDI-Werkzeughalter ER, Form E4

VDI Tool Holders ER, Form E4



Bestell-Nr. order-no.	D	Zange collet	d1 min	d1 max	d2	d3	H	L
EU16V16	16	ER16	1	10	28	40	13	41
EU20V16	16	ER20	1	13	34	40	13	40
EU16V20	20	ER16	1	10	28	50	20	43
EU20V20	20	ER20	1	13	34	50	23	47
EU25V20	20	ER25	1	16	42	50	25	50
EU32V20	20	ER32	2	20	50	50	30	57
EU25V25	25	ER25	1	16	42	58	20	52
EU32V25	25	ER32	2	20	50	58	20	58
EU25V30	30	ER25	1	16	42	68	25	50
EU32V30	30	ER32	2	20	50	68	30	57
EU40V30	30	ER40	3	30	63	68	32	63
EU25V40	40	ER25	1	16	42	83	25	52
EU32V40	40	ER32	2	20	50	83	29	58
EU40V40	40	ER40	3	30	63	83	32	63

ER-Zangenspannfutter MK mit Morsekonus DIN 2207

ER-Collet Holders MT with Morse Taper DIN 2207

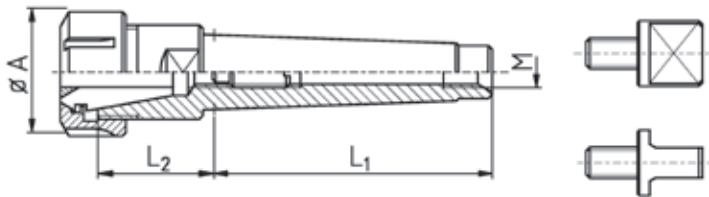

Bestell-Nr. order-no.	Typ / MK type / MT	Zange collet	M	L ₁	L ₂	A	Mutter nut	Schlüssel spanner
EM16MK1	ER16/MK1	ER16	M6	57	31	22	ER16M	E16M
EU11MK1	ER11 / MK1	ER11	M6	57	12	19	UM/ER11	GS17
EU16MK1	ER16 / MK1	ER16	M6	57	31	28	UM/ER16	GS25
EU16MK2	ER16 / MK2	ER16	M10	67	32	28	UM/ER16	GS25
EU16MK3	ER16 / MK3	ER16	M12	86	30	28	UM/ER16	GS25
EU20MK2	ER20 / MK2	ER20	M10	68	32	34	UM/ER20	GS30
EU25MK2	ER25 / MK2	ER25	M10	68	35	42	UM/ER25	E25
EU25MK2L	ER25 / MK2	ER25	--	80	52	42	UM/ER25	E25
EU25MK3	ER25 / MK3	ER25	M12	86	38	42	UM/ER25	E25
EU25MK4	ER25 / MK4	ER25	M16	109	37	42	UM/ER25	E25
EU32MK2	ER32 / MK2	ER32	M10	69	32	50	UM/ER32	E32
EU32MK3	ER32 / MK3	ER32	M12	86	52	50	UM/ER32	E32
EU32MK3K	ER32 / MK3	ER32	M12	86	40	50	UM/ER32	E32
EU32MK3L	ER32 / MK3	ER32	--	99	55	50	UM/ER32	E32
EU32MK4	ER32 / MK4	ER32	M15	108	48	50	UM/ER32	E32
EU40MK3	ER40 / MK3	ER40	M12	86	55	63	UM/ER40	E40
EU40MK4	ER40 / MK4	ER40	M15	109	55	63	UM/ER40	E40
EU40MK5	ER40 / MK5	ER40	M19	135	60	63	UM/ER40	E40
EU50MK4	ER50 / MK4	ER50	M15	109	68	78	UM/ER50	E50
EU50MK5	ER50 / MK5	ER50	M19	136	70	78	UM/ER50	E50

MK-Futter auch mit Zangenaufnahme DIN 6388
(OZ16, OZ25, OZ32) lieferbar

Morse taper holders also available with
collet taper DIN 6388 (OZ)



Austreiberlappen für MK-Futter

Ejector Drift for MT-Holders

Bestell-Nr. - order-no.	TAG1	TAG2	TAG3	TAG4	TAG5
Gewinde - thread	M6	M10	M12	M16	M20

ER-Zangenspannfutter SK mit Steilkegelschaft für GILDEMEISTER

ER-Collet Holders BT Type for GILDEMEISTER

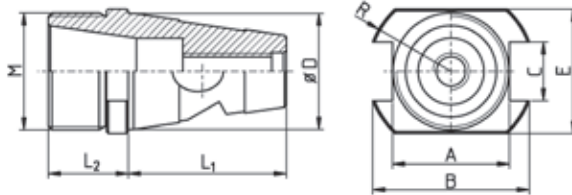

Bestell-Nr. order-no.	Typ / SK type / bt	Zange collet	M	L ₁	L ₂	A	B	C	E	R	Mutter nut	Schlüssel spanner
EU20ISO25	ER20 / ISO25	ER20	M25x1,5	42	19,7	25,9	32	12	32	14	UX/ER20	E20
EU20ISO30G	ER20 / ISO30	ER20	M25x1,5	43,5	22,6	32,2	43	16,1	34	21,2	UX/ER20	E20
EU20ISO30K	ER20 / ISO30	ER20	M25x1,5	43,5	22,8	34	--	--	32,6	17,4	UX/ER20	E20
EM25ISO30G	ER25M / ISO30	ER25	M30x1	43,5	22,6	32	43	16,1	34	21,2	ER25M	E25M
EM25ISO30K	ER25M / ISO30	ER25	M30x1	43,5	22,5	34	--	--	32,5	18,5	ER25M	E25M
EU25ISO30G	ER25 / ISO30	ER25	M32x1,5	43,5	22,5	32,2	43	16,1	34	22,5	UM/ER25	E25
EU25ISO30K	ER25 / ISO30	ER25	M32x1,5	43,5	22	34	--	--	32,7	18	UM/ER25	E25
EU32ISO30	ER32 / ISO30	ER32	M40x1,5	43,5	31	32,2	43	16,1	37,8	22	UM/ER32	E32
EU32ISO40	ER32 / ISO40	ER32	M40x1,5	67,5	26	25*	*	20	50	32,25	UM/ER32	E32
EU40ISO40	ER40 / ISO40	ER40	M50x1,5	67,5	25	25*	*	20	50	32,25	UM/ER40	E40

* Nut einseitig

* Groove onesided



UX/ER20 = M25 x 1,5



ER25M = M30 x 1



UM/ER25 = M32 x 1,5



UM/ER32 = M40 x 1,5



UM/ER40 = M50 x 1,5

ER-Zangenspannfutter 2 Achsen verstellbar

ER-Collet Holders 2 Axis Adjustable



Bild 1



Bild 2

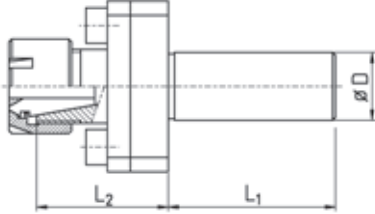

Bestell-Nr. order-no.	Zange collet	D	L ₁	L ₂	Bild picture	Mutter nut	Schlüssel spanner
V154.016	ER16	16	50	36	1	ER16M	E16M
V154.019	ER16	3/4"	50	36	1	ER16M	E16M
V154.020	ER16	20	50	36	1	ER16M	E16M
V154.022	ER16	22	70	36	1	ER16M	E16M
V154.025	ER16	25	70	36	1	ER16M	E16M
V154.026	ER16	1"	70	36	1	ER16M	E16M
V154.219	ER20	3/4"	44	43	2	ER20M	E20M
V154.220	ER20	20	44	43	2	ER20M	E20M
V154.326	ER32	1"	50	46	2	UM/ER32	E32

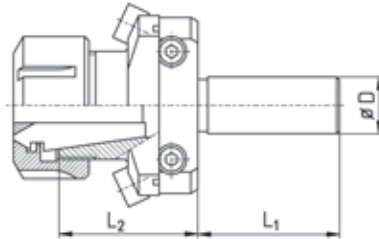

ER16M = M19 x 1



ER20M = M24 x 1



UM/ER32 = M40 x 1,5

Bohrverlängerungen mit ER-Zangenspannfutter

Drill Extensions with ER-Collet holders

Bestell-Nr. order-no.	Zange collet	M	D	L
WT16ER11	ER11	M16x1	20	21
WT16ER16	ER16	M16x1	20	24
WT17ER11	ER11	M17x1	20	21
WT22ER16	ER16	M22x1	27	22

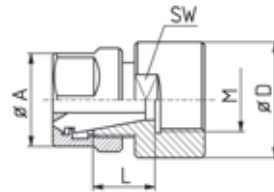

Spannzangenreduktion *Collet Reduction*



Spannzangenreduktionen mit Überwurfmutter UF

Collet Reduction with Cap Nut UF



Bild 1



Bild 2

Bestell-Nr. order-no.	Kegel cone	Zange collet	UF-Mutter, Gewinde cap nut, thread	M	A ₁	A ₂	L ₁	L ₂	L	G
EQ11M/ER08	ER11	ER08	M13 x 0,75		12	19	8		28	M4
EQ11/ER08	ER11	ER08	M14 x 0,75		12	20	8		28	M4
EQ11M/ER16M	ER11	ER16 #	M13 x 0,75		22	19	27		47	-
EQ11/ER16M	ER11	ER16 #	M14 x 0,75		22	20	27		47	-
EQ11M/ER16	ER11	ER16 #	M13 x 0,75							
EQ11/ER16	ER11	ER16 #	M14 x 0,75		22	20	38	41	56	-
EQ16M/F8L	ER16	F8	M19 x 1		20	SW22	50,5	53,5	70	M8
EQ16/F8L	ER16	F8	M22 x 1,5 *		20	28	50,5	53,5	70	M8
EQ16M/F8	ER16	F8	M19 x 1		20	SW22	31	34	53	M8
EQ16/F8	ER16	F8	M22 x 1,5 *		20	28	31	34	53	M8
EQ16M/ER08M	ER16	ER08	M19 x 1		12	SW22	27	30	48	M8
EQ16/ER08M	ER16	ER08	M22 x 1,5		12	28	27	30	48	M8
EQ16M/ER08ML	ER16	ER08	M19 x 1		12	SW22	44	47	66	M8
EQ16/ER08ML	ER16	ER08	M22 x 1,5		12	28	44	47	66	M8
EQ16M/ER08M-HS207**	ER16	ER08	M19 x 1		12	SW22	41	44	66	M8
EQ16/ER08M-HS207**	ER16	ER08	M22 x 1,5		12	28	41	44	66	M8
EQ16M/ER11M	ER16	ER11	M19 x 1		16	SW22	16	19	38	M8
EQ16/ER11M	ER16	ER11	M22 x 1,5 *		16	28	16	19	38	M8
EQ16M/ER11ML	ER16	ER11	M19 x 1		16	SW22	32	35	57	M8
EQ16/ER11ML	ER16	ER11	M22 x 1,5 *		16	28	32	35	57	M8
EQ16M/ER11MXL	ER16	ER11	M19 x 1		16	SW22	53	56	78	M8
EQ16/ER11MXL	ER16	ER11	M22 x 1,5 *		16	28	53	56	78	M8
EQ20M/ER11M	ER20	ER16	M24 x 1		16	28	22	25	42	M8
EQ20/ER11M	ER20	ER16	M25 x 1,5		16	35	22	25	42	M8
EQ20M/ER16M	ER20	ER16	M24 x 1		22	28	22	25	48	M10
EQ20/ER16M	ER20	ER16	M25 x 1,5		22	35	25	28	48	M10
EQ25M/ER11M	ER25	ER11	M30 x 1		16	35	20	23	58	M12
EQ25/ER11M	ER25	ER11	M32 x 1,5		16	42	20	23	58	M10
EQ25M/ER11ML	ER25	ER11	M30 x 1		16	35	42	45	71	M12
EQ25/ER11ML	ER25	ER11	M32 x 1,5		16	42	42	45	71	M12
EQ25M/ER16M	ER25	ER16	M30 x 1		22	35	25	28	55	M12
EQ25/ER16M	ER25	ER16	M32 x 1,5		22	42	25	28	55	M12
EQ25M/ER16ML	ER25	ER16	M30 x 1		22	35	33	36	63	M12
EQ25/ER16ML	ER25	ER16	M32 x 1,5		22	42	33	36	63	M12
EQ25M/ER20	ER25	ER20	M30 x 1		34	35	16	19	50	M10
EQ25/ER20	ER25	ER20	M32 x 1,5		34	42	16	19	50	M10

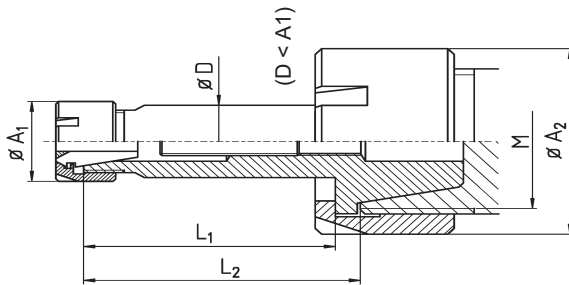
Incl. Überwurfmutter

* Auch mit Mutter M22x1,25 (für TORNOS AS14/SAS16)

Vergrößerung auf ER16

** Zur Aufnahme von Zange und Säge (Bild 2)

Supplied with cap nut

* Also available with M22x1,25 (for TORNOS AS14/SAS16)

Increases ER11 to ER16

** For collet and milling cutter (Bild 2)

Collet Reduction

ER Überwurfmutter für Fräsdorne und Spannzangenreduktionen

ER Cap Nuts for Milling Arbors and Collet Reduction Sleeves

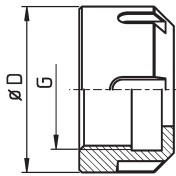

Bestell-Nr. order-no.	D	Gewinde thread G	Schlüssel spanner
UF/ER08M	16	M10x0,75	GS14
UF/ER11	19	M14x0,75	GS17
UF/ER11M	19,5	M13x0,75	GS17
UF/ER16	28	M22x1,5	GS25
UF/ER16M	SW22	M19x1	GS22
UF/ER20	35	M25x1,5	GS30
UF/ER20M	28	M24x1	E20M-XX
UF/ER25	42	M32x1,5	E25
UF/ER25M	35	M30x1	E25M-XX

Spannzangenreduktionen mit Standardmutter

Collet Reduction Sleeves with Standard Nut

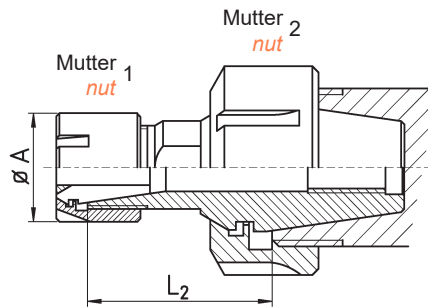
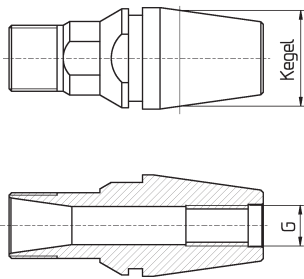

Bestell-Nr. order-no.	Kegel cone	Zange collet	Mutter nut 1	Mutter nut 2	A	L_2	G	SW
EQS20M/ER11M	ER20	ER11	ER11M	ER20M	16	24	M8x1	13
EQS20/ER11M	ER20	ER11	ER11M	UM/ER20	16	22	M8x1	14
EQS20M/ER16M	ER20	ER16	ER16M	ER20M	22	24	M8x1	13
EQS20/ER16M	ER20	ER16	ER16M	UM/ER20	22		M8x1	19
EQS25M/ER11M	ER25	ER11	ER11M	ER25M	16	35	M8x1	14
EQS25/ER11M	ER25	ER11	ER11M	UM/ER25	16	33	M8x1	14
EQS32/ER11M	ER32	ER11	ER11M	UM/ER32	16	25	M10x1	14

Incl. Mutter 1

Supplied with nut 1

ER - Doppelhalter *ER - Double Holders*



passion for clamping

ER-Doppelhalter für CNC-Maschinen mit Abgreifspindel

ER-Double Holders for CNC-Lathes with Subspindle

Ausführungen:

Versions:

FL: Spannfläche abgesetzt
FL: Enclosed clamping flat

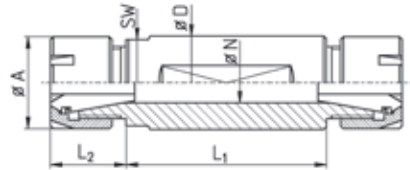

WD: Spannfläche durchgehend
WD: Clamping flat throughout

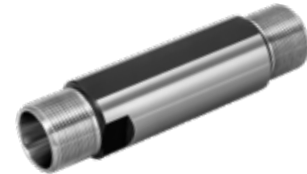

Bestell-Nr. order-no.	Zange collet	D	L ₁	L ₂	A	N	SW	Mutter nut	Schlüssel spanner
ED085818WD	ER08	5/8"	18	9	12	5,5	14	ER08M	E08M
ED085829WD	ER08	5/8"	29	9	12	5,5	14	ER08M	E08M
ED085835WD	ER08	5/8"	35	10	12	5,5	14	ER08M	E08M
ED085840WD	ER08	5/8"	40	10	12	5,5	14	ER08M	E08M
ED085845WD	ER08	5/8"	45	10	12	5,5	14	ER08M	E08M
ED115832WD	ER11	5/8"	32	12	16	7,5	14	ER11M	E11M
ED111632WD	ER11	16	32	12	16	7,5	14	ER11M	E11M
ED111650WD	ER11	16	50	12	16	7,5	14	ER11M	E11M
ED111672WD	ER11	16	72	12	16	7,5	14	ER11M	E11M
ED1116100WD	ER11	16	100	12	16	7,5	14	ER11M	E11M
ED111932WD	ER11	3/4"	32	12	16	7,5	17	ER11M	E11M
ED111940WD	ER11	3/4"	40	12	16	7,5	17	ER11M	E11M
ED111952WD	ER11	3/4"	52	12	16	7,5	17	ER11M	E11M
ED111965WD	ER11	3/4"	65	12	16	7,5	17	ER11M	E11M
ED111972WD	ER11	3/4"	72	12	16	7,5	17	ER11M	E11M
ED111995WD	ER11	3/4"	95	12	16	7,5	17	ER11M	E11M
ED112032WD	ER11	20	32	10	16	7,5	--	ER11M	E11M
ED112040WD	ER11	20	40	10	16	7,5	17	ER11M	E11M
ED112050WD	ER11	20	50	10	16	7,5	17	ER11M	E11M
ED112065WD	ER11	20	65	12	16	7,5	17	ER11M	E11M
ED112080WD	ER11	20	80	12	16	7,5	17	ER11M	E11M
EDU112080WD	ER11	20	80	12	16	7,5	17	UM/ER11	GS17
ED112232WD	ER11	22	32	12	16	7,5	19	ER11M	E11M
EDU112295WD	ER11	22	95	12	16	7,5	19	UM/ER11	GS17
EDU1122100WD	ER11	22	100	12	16	7,5	19	UM/ER11	GS17
ED161928FL	ER16	3/4"	28	14	22	11	17	ER16M	E16M
ED161934FL	ER16	3/4"	34	14	22	11	17	ER16M	E16M
ED161937FL	ER16	3/4"	37	12	22	11	17	ER16M	E16M
ED161958FL	ER16	3/4"	58	13	22	11	17	ER16M	E16M
ED161967FL	ER16	3/4"	67	14	22	11	17	ER16M	E16M
ED161975FL	ER16	3/4"	75	13	22	11	17	ER16M	E16M
ED161995FL	ER16	3/4"	95	15	22	11	17	ER16M	E16M
ED1619100FL	ER16	3/4"	102	14	22	11	17	ER16M	E16M
ED162032WD	ER16	20	32	15	22	11	17	ER16M	E16M
ED162050WD	ER16	20	50	15	22	11	17	ER16M	E16M
ED162055FL	ER16	20	55	15	22	11	17	ER16M	E16M
ED162062FL	ER16	20	62	15	22	11	17	ER16M	E16M
ED162075FL	ER16	20	75	15	22	11	17	ER16M	E16M
ED162240WD	ER16	22	40	15	22	11	19	ER16M	E16M
ED162248WD	ER16	22	48	15	22	11	19	ER16M	E16M
ED162255WD	ER16	22	55	15	22	11	19	ER16M	E16M
ED162262WD	ER16	22	62	15	22	11	19	ER16M	E16M

Bestell-Nr. order-no.	Zange collet	D	L ₁	L ₂	A	N	SW	Mutter nut	Schlüssel spanner
ED162267WD	ER16	22	67	14	22	11	19	ER16M	E16M
ED162275WD	ER16	22	75	15	22	11	19	ER16M	E16M
ED162284WD	ER16	22	84	16	22	11	19	ER16M	E16M
ED162290WD	ER16	22	90	16	22	11	19	ER16M	E16M
ED162295WD	ER16	22	95	16	22	11	19	ER16M	E16M
ED1622100WD	ER16	22	100	16	22	11	19	ER16M	E16M
ED1622120WD	ER16	22	120	15	22	11	19	ER16M	E16M
ED162360WD	ER16	23	60	16	22	11	19	ER16M	E16M
ED162562WD	ER16	25	62	16	22	11	22	ER16M	E16M
ED162621WD	ER16	1"	21	14	22	11	--	ER16M	E16M
ED162635WD	ER16	1"	35	14	22	11	--	ER16M	E16M
ED162635FL	ER16	1"	35	15	22	11	22	ER16M	E16M
ED162645FL	ER16	1"	45	15	22	11	22	ER16M	E16M
ED162645WD	ER16	1"	45	15	22	11	22	ER16M	E16M
ED162662WD	ER16	1"	62	16	22	11	22	ER16M	E16M
ED162668WD	ER16	1"	68	14	22	11	22	ER16M	E16M
ED162675FL	ER16	1"	75	15	22	11	22	ER16M	E16M
ED162680WD**	ER16	1"	80	17	22	11	22	ER16M	E16M
ED202548WD	ER20	25	48	16	28	14	22	ER20M	E20M
ED202575WD	ER20	25	75	16	28	14	22	ER20M	E20M
ED2025100WD	ER20	25	100	15	28	14	22	ER20M	E20M
ED202645WD	ER20	1"	45	16	28	14	--	ER20M	E20M
ED202675WD	ER20	1"	75	15	28	14	22	ER20M	E20M
ED203220WD	ER20	32	20	18	28	14	-	ER20M	E20M
ED203235WD	ER20	32	35	18	28	14	-	ER20M	E20M
ED203243WD	ER20	32	43	18	28	14	27	ER20M	E20M
ED203243FL	ER20	32	43	18	28	14	27	ER20M	E20M
ED203248WD	ER20	32	48	18	28	14	27	ER20M	E20M
ED203255WD	ER20	32	55	18	28	14	27	ER20M	E20M
ED203285WD	ER20	32	85	18	28	14	27	ER20M	E20M
EDU162680WD*	ER16	1"	80	17	22	11	22	UM/ER16	GS25
EDU253252FL	ER25	32	52	16	42	17	-	UM/ER25	E25

* 1. Seite ER16 Standard / 2. Seite ER16 Mini
 ** mit Langlochbohrung im Schaft

* 1. thread ER16 standard / 2. thread ER16 mini
 ** with oval bore in the shank

ER-Doppelhalter können gegen Aufpreis auf AK1-Anschluss (G1/8") umgearbeitet werden
 ER-double holders can be changed to AK1-inner-coolant (G1/8") for extra charge



ER08M = M10 x 0,75



ER11M = M13 x 0,75



UM/ER11 = M14 x 0,75



ER16M = M19 x 1



UM/ER16 = M22 x 1,5



ER20M = M24 x 1



UM/ER25 = M32 x 1,5

ER-Doppelhalter mit unterschiedlichen Zangengrößen

ER-Double Holders with Different Collet Sizes

Ausführungen:
Versions:

FL: Spannfläche abgesetzt
FL: Enclosed clamping flat

WD: Spannfläche durchgehend
WD: Clamping flat throughOut

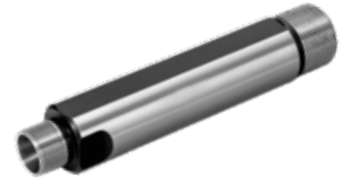
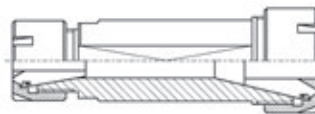
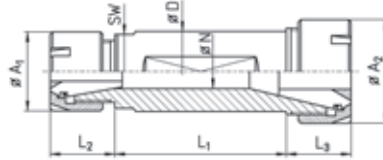

Bestell-Nr. order-no.	Zangen collets	D	L ₁	L ₂	L ₃	A ₁	A ₂	N	SW	Mutter nut	Schlüssel spanner
ED11/161680FL	ER11/16	16	80	12	21	16	22	7,5	17	ER11M / ER16M	E11M / E16M
ED11/161933FL	ER11/16	3/4"	33	12	14	16	22	7,5	17	ER11M / ER16M	E11M / E16M
ED11/161955FL	ER11/16	3/4"	55	12	13	16	22	7,5	17	ER11M / ER16M	E11M / E16M
ED11/161965WD	ER11/16	3/4"	65	12	14	16	22	7,5	17	ER11M / ER16M	E11M / E16M
EDU11/161983FL	ER11/16	3/4"	83	12	12	16	22	7,5	17	UM/ER11 / ER16M	GS17 / E16M
ED11/161996FL	ER11/16	3/4"	96	12	14	16	22	7,5	17	ER11M / ER16M	E11M / E16M
ED11/162032WD	ER11/16	20	32	12	15	16	22	7,5	17	ER11M / ER16M	E11M / E16M
ED11/162050FL	ER11/16	20	50	11	15	16	22	7,5	17	ER11M / ER16M	E11M / E16M
ED11/162050WD	ER11/16	20	50	11	15	16	22	7,5	17	ER11M / ER16M	E11M / E16M
ED11/162055WD	ER11/16	20	55	12	15	16	22	7,5	17	ER11M / ER16M	E11M / E16M
EDU11/162082WD	ER11/16	20	82	11	12	16	22	7,5	-	UM/ER11 / UM/ER16	GS17 / GS25
EDU11/162290WD	ER11/16	22	90	12	16	19	22	7,5	19	UM/ER11 / ER16M	GS17 / E16M
EDU11/162292FL	ER11/16	22	92	12	16	19	22	7,5	19	UM/ER11 / ER16M	GS17 / E16M
EDU11/162292AK1WD	ER11/16	22	92	12	16	19	22	7,5	G1/8"	UM/ER11 / ER16M	GS17 / E16M
ED16/202265	ER16/20	22	65	23	25	22	28	11	19	ER16M / ER20M	E16M / E20M
ED16/202630WD	ER16/20	1"	30	16	16	22	28	11	-	ER16M / ER20M	E16M / E20M
ED16/202660FL	ER16/20	1"	60	15	15	22	28	11	22	ER16M / ER20M	E16M / E20M
ED16/252560WD	ER16/25	25	60	12	14	22	35	11	23	ER16M / ER25M	E16M / E25M
ED20/252562FL	ER20/25	25	62	22	22	28	35	14	27	ER20M / ER25M	E20M / E25M
ED20/252575WD	ER20/25	25	75	18	29	28	35	14	27	ER20M / ER25M	E20M / E25M
ED20/252662FL	ER20/25	1"	62	24	34	28	35	14	27	ER20M / ER25M	E20M / E25M
ED20/253250WD	ER20/25	32	50	25	25	28	35	14	27	ER20M / ER25M	E20M / E25M
ED20/253255WD	ER20/25	32	55	25	25	28	35	14	27	ER20M / ER25M	E20M / E25M



ER11M = M13 x 0,75



UM/ER11 = M14 x 0,75



ER16M = M19 x 1



UM/ER16 = M22 x 1,5



ER20M = M24 x 1

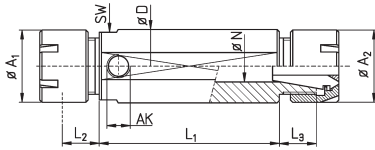

ER25M = M30 x 1

**ER-Doppelhalter
mit innerer Kühlmittelzufuhr**
**ER-Double Holders
with Inner Coolant**

Bestell-Nr. order-no.	Zange collet	D	L ₁	L ₂	L ₃	A	N	AK	SW	Mutter nut	Schlüssel spanner
ED11/162280AK1WD	ER11/16	22	80	13	16	19/22	7,5	G1/8"	-	ER11M/ERC16M	E11M/E16M
ED11/162295AK1WD	ER11/16	22	91	13	16	19/22	7,5	G1/8"	-	ER11M/ERC16M	E11M/E16M
ED11/162295AK2WD	ER11/16	22	95	13	16	19/22	7,5	M8x1	-	ER11M/ERC16M	E11M/E16M
ED11/162295AK3WD	ER11/16	22	95	13	16	19/22	7,5	M10x1	-	ER11M/ERC16M	E11M/E16M
ED162254AK1WD	ER16	22	54	16	16	22	11	G1/8"	-	ERC16M	E16M
ED162257AK1WD	ER16	22	57	16	16	22	11	G1/8"	-	ERC16M	E16M
ED162265AK1WD	ER16	22	65	16	16	22	11	G1/8"	-	ERC16M	E16M
ED162267AK1WD	ER16	22	67	16	16	22	11	G1/8"	-	ERC16M	E16M
ED162270AK1WD	ER16	22	70	16	16	22	11	G1/8"	19	ERC16M	E16M
ED162270AK2WD	ER16	22	70	16	16	22	11	M8x1	19	ERC16M	E16M
ED162289AK1WD	ER16	22	89	16	16	22	11	G1/8"	-	ERC16M	E16M
ED162294AK1WD	ER16	22	94	15	15	22	11	G1/8"	-	ERC16M	E16M
ED1622100AK1WD	ER16	22	100	16	16	22	11	G1/8"	-	ERC16M	E16M
ED16/202260AK1WD	ER16/20	22	60	16	18	22/28	11	G1/8"	-	ERC16M/ERC20M	E16M/E20M
ED16/202265AK1WD	ER16/20	22	65	16	18	22/28	11	G1/8"	-	ERC16M/ERC20M	E16M/E20M
ED16/202270AK1WD	ER16/20	22	70	15	15	22/28	11	G1/8"	19	ERC16M/ERC20M	E16M/E20M
ED203244AK2WD	ER20	32	44	18	18	28	14	M8x1	-	ERC20M	E20M
ED203255AK1WD	ER20	32	55	18	18	28	14	G1/8"	27	ERC20M	E20M
ED203255AK2WD	ER20	32	55	18	18	28	14	M8x1	27	ERC20M	E20M
ED203265AK1WD	ER20	32	64	18	18	28	14	G1/8"	-	ERC20M	E20M
ED203285AK1WD	ER20	32	85	18	18	28	14	G1/8"	27	ERC20M	E20M

Alle Halter AK0 können auf AK1 - AK3 reduziert werden

All holders AK0 can be reduced to AK1 - AK3



ER11M = M13 x 0,75



ERC16M = M19 x 1



ERC20M = M24 x 1

für Dichtscheiben - for sealing disks

Zangenspannfutter Div.
Collet Holders Div.



passion for clamping

Zangenspannfutter DIN 6388 für OZ-Zangen

Collet Holders DIN 6388 for OZ-Collets

Bild 1



Bild 2



Bestell-Nr. order-no.	Zange Form A collet type A	Zange Form B collet type B	D	L ₁	L ₂	A	SW	Bild picture	Mutter nut
EOZ162550FL	410E	415E	25	50	49	43	30	1	OZ16
EOZ16MK2	410E	415E	MK2 / MC2		45	43	24	2	OZ16
EOZ16MK3	410E	415E	MK3 / MC3		41	43	24	2	OZ16
EOZ16MK4	410E	415E	MK4 / MC4		32	43	30	2	OZ16
EOZ16MK5	410E	415E	MK5 / MC5			43		2	OZ16
EOZ253260FL-CNC	444E	462E	32	60		58		1	OZ25
EOZ253268FL-CNC	444E	462E	32	68	52	58	-	1	OZ25
EOZ25MK2	444E	462E	MK2 / MC2		55	58	41	2	OZ25
EOZ25MK3	444E	462E	MK3 / MC3		59	58	32	2	OZ25
EOZ25MK4	444E	462E	MK4 / MC4		62	58	32	2	OZ25
EOZ25MK5	444E	462E	MK5 / MC5		56	58	45	2	OZ25
EOZ254080FL-S	444E	462E	40	80	36	58	41	1	OZ25
EOZ255080FL-S-CNC	444E	462E	50	80	25	58	-	1	OZ25
EOZ32MK4	450E	467E	MK4 / MC4		61	72	45	2	OZ32
EOZ32MK5	450E	467E	MK5 / MC5		62	72	45	2	OZ32
EOZ3232100	450E	467E	32	100	67	72	46	1	OZ32
EOZ3232100FL-CNC	450E	467E	32	100	67	72	46	1	OZ32
EOZ40MK4	453E	468E	MK4 / MC4		88	85	45	2	OZ40
EOZ40MK5	453E	468E	MK5 / MC5		88	85	45	2	OZ40

Austreiberlappen für MK-Futter

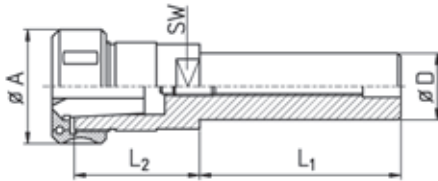
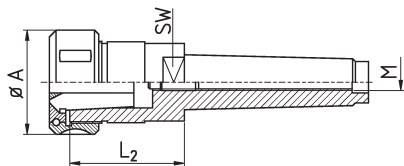
Ejector Drift for MT-Holders



Siehe S. 30

see page 30

Zangenspannfutter für Zangen Reihe 100 mit Zylinderschaft

Collet Holders for Collets Type 100 with Cylindrical Shank

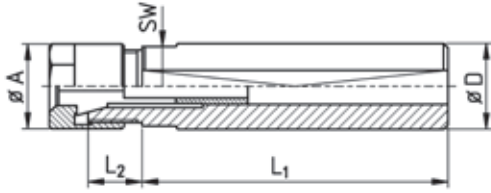

Bestell-Nr. order-no.	Zange collet	D	L ₁	L ₂	A	SW	Mutter nut
EF101/1630	101E / F8	16	30	18	20	14	UM/E101
EF101/1680	101E / F8	16	80	18	20	14	UM/E101
EF101/1970	101E / F8	3/4"	70	18	20	17	UM/E101
EF101/2070	101E / F8	20	70	18	20	17	UM/E101
EF101/20125	101E / F8	20	125	18	20	17	UM/E101
EF101/22125	101E / F8	22	125	18	20	17	UM/E101
EF109/22125	109E / F10	22	125	24	28	19	UM/E101

Klemmkonusse

Clamp Cones

Für Zangenaufnahmen Reihe 100 (Typ F)

For collet holders type 100 (type F)

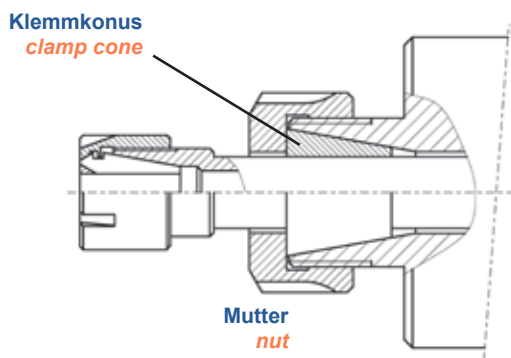

Bestell-Nr. order-no.	Typ type	ersetzt Zange Nr. replaces collet no.
KKF8-16	8 - 16°	101E / F8
KKF10-20	10 - 20°	109E / 111E / F10

Muttern = Überwurfmutter für F-Spannzangen, tw. weitere auf Anfrage
Nuts = Cap nuts for collets type F, some available on request

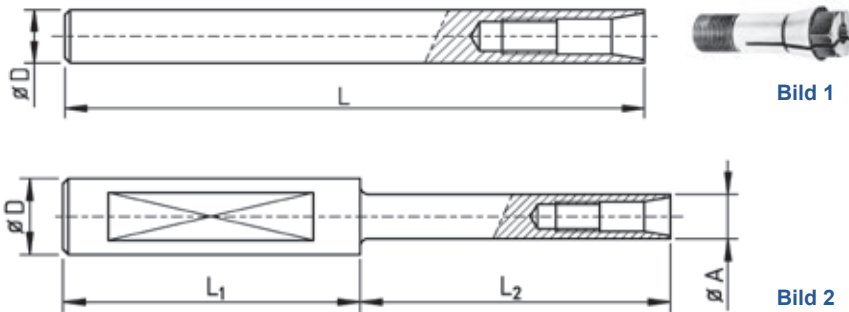

Aufnahmen gehärtet und geschliffen

HOLDERS are hardened and ground

Bestell-Nr. order-no.	Zange collet	D	L	L ₁	L ₂	A	Bild picture
E6023/06100	6023E	6	100	80	20	7,2	2
E6023/07100	6023E	7	100	-	-	-	1
E6023/0870	6023E	8	70	-	-	-	1
E6023/08100	6023E	8	100	-	-	-	1
E6023/08150	6023E	8	150	-	-	8	1
E6023/08200	6023E	8	200	-	-	8	1
E6023/08250 #	6023E	8	250	-	-	8	1
E6023/08300 #	6023E	8	300	-	-	8	1
E6023/08350 #	6023E	8	350	-	-	8	1
E6023/08400 #	6023E	8	400	-	-	8	1
E6043/0930	6043E	9	30	-	-	-	1
E6043/0940	6043E	9	40	-	-	-	1
E6043/09100	6043E	9	100	-	-	-	1
E6043/10100S	6043E	10	100	50	50	9	2
E600/10100	600E	10	100	-	-	-	1
E600/10125	600E	10	125	-	-	-	1
E601/12100	601E	12	100	-	-	-	1
E601/16100	601E	16	100	-	-	-	1
E601/16160	601E	16	160	-	-	-	1
E601/1890-2WD	601E	18	90	-	-	-	1

Aus Vergütungsstahl

#: Material = HSS

Klemmfläche oder Durchgangsbohrungen mit Aufpreis

Material: Heat-treated steel

#: Material = HSS

Clamping flat or through-bore for extra charge

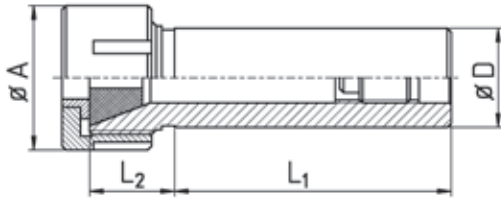

Bestell-Nr. order-no.	Orig. Nr. TRAUB / INDEX orig.-no. TRAUB / INDEX	Zange collet	D	L ₁	L ₂	A	Bereich range	Mutter nut
ROZ 3161	Tb 315 003 W12.126.0046	41	3/4"	46	19	21	1 - 6,5	ROZ 3157
ROZ 3162		41	16mm	46	19	21	1 - 6,5	ROZ 3157
ROZ 3164FL		41	20	70	19	21	1 - 6,5	ROZ 3157
ROZ 3170	Tb 315 005 W12.121.0046	42	3/4"	46	19	31	2 - 10	ROZ 3158
ROZ 3171	Tb 614 666	42	1"	46	19	31	2 - 10	ROZ 3158
ROZ 3172*		42	25mm	46	19	31	2 - 10	ROZ 3158
ROZ 3173*		42	20mm	46	19	31	2 - 10	ROZ 3158
ROZ 3180	Tb 614 665 W32.121.00	44	1"	46	33	40	1,8 - 13 (15)	ROZ 3159
ROZ 3182*		44	25mm	46	33	40	1,8 - 13 (15)	ROZ 3159
ROZ 3184*		44	20mm	46	33	40	1,8 - 13 (15)	ROZ 3159
ROZ 3185		44	3/4"	46	33	40	1,8 - 13 (15)	ROZ 3159

* Auch mit Klemmfläche lieferbar

* Also available with clamping flat

Pendelhalter

Reamer Holders



passion for clamping

Technische Informationen

Technical Information

- Pendelhalter können zum Ausgleich von Fluchtungsfehlern auch für starres Gewindebohren auf CNC-Werkzeugmaschinen eingesetzt werden
- Alle Pendelhalter werden incl. Standard-Mutter geliefert
- Pendelhalter mit "AK" werden incl. abgedichteter Mutter (System Rego-fix) geliefert.
- Abkürzungen bei den Halter-Bezeichnungen siehe auch Technische Informationen Seite 4 + 5
- Bei Haltern mit Kühlmittelanschluss:
IK = axialer Kühlmittelanschluss
AK = seitlicher (radialer) Kühlmittelanschluss
Gewinde des Kühlmittelanschlusses:
AK0 = M12x1,5
AK1 = G1/8"
AK2 = M8x1
AK3 = M10x1
Alle Halter AK0 können auf AK1 - AK3 reduziert werden
- Einstellen des Freipendelns bei Haltern mit dieser Option:
 - Schwarze Schrauben auf der vorderen Stirnseite leicht lösen.
 - Blanke Schraube ganz herausdrehen. Unter dieser befindet sich die Lochung zum Einstellen des Freipendelns.
 - Ist die gewünschte Einstellung erreicht, alle Schrauben wieder anziehen
- Siehe auch Katalog:
"Werkstück- und Werkzeugspannung" :
Spannzangen mit pendelndem Ausgleich (S. 50)
- *Reamer holders could be used for compensate misalignment while tapping on CNC-machines*
- *All reamer holders will be supplied with clamping nut (standard)*
- *Reamer holders with "AK" will be supplied with sealed nut type Rego-fix*
- *Abbreviations for holders see technical information page 4 + 5*
- *Holders with inner coolant inlet:
IK = axial coolant inlet
AK= radial coolant inlet*

*Thread of coolant inlet:
AK0 = M12x1.5
AK1 = G1/8"
AK2 = M8x1
AK3 = M10x1*

All holders with coolant inlet AK0 can be reduced to AK1 - AK3
- *Adjusting of axial float:
- Release frontal black screws
- Silver screw has to be removed completely.
Below this screw are the bores to adjust
- After adjusting tighten all screws*
- *See also catalog:
"Workpiece & Tool Clamping" :
Floating Reamer Collets (p. 50)*

Pendelhalter ER11 mit Kühlmittelanschluss

- 1 mm Pendelweg in alle Richtungen
- Sehr schmal gebaut
- Exakt paralleles Pendeln
- Selbstzentrierend
- Kein Abkippen möglich
- Incl. Standardmutter ER11M

Reamer Holders ER11 with Inner Coolant

- 1 mm float in all directions
- Compact dimensions
- Self-centering
- Non tilting possible
- Incl. standard nut ER11M

Bestell-Nr. order-no.	D	C	B	L ₁	L ₂	G
PH111032	10	45	24	32	32	*
PH111040	10	45	24	40	32	*
PH111232	12	45	24	32	32	*
PH111240	12	45	24	40	32	*
PH111445IK	14	45	24	45	32	G1/8"
PH111650IK	16	45	24	50	32	G1/8"
PH111680IK	16	45	24	80	32	G1/8"
PH111950IK	3/4"	45	24	50	32	G1/8"
PH111970IK	3/4"	45	24	70	32	G1/8"
PH1119120IK	3/4"	45	24	120	32	G1/8"
PH112050IK	20	45	24	50	32	G1/8"
PH112070IK	20	45	24	70	32	G1/8"
PH112250IK	22	45	24	50	32	G1/8"
PH112270IK	22	45	24	70	32	G1/8"
PH1122120IK	22	45	24	120	32	G1/8"
PH112550IK	25	45	24	50	32	G1/8"
PH112570IK	25	45	24	70	32	G1/8"
PH112650IK	1"	45	24	50	32	G1/8"
PH112670IK	1"	45	24	70	32	G1/8"
PH112870IK	28	45	24	70	32	G1/8"
PH111032AK1	10	45	24	32	40	G1/8"
PH111232AK1	12	45	24	32	40	G1/8"
PH111650AK1	16	45	24	50	40	G1/8"
PH112050AK1	20	45	24	50	37	G1/8"
PH112070AK1	20	45	24	70	37	G1/8"
PH112250AK1	22	45	24	50	37	G1/8"
PH112550AK1	25	45	24	50	42	G1/8"
PH112570AK1	25	45	24	70	42	G1/8"
PH1125140AK1	25	45	24	140	37	G1/8"
PH1122SRRAK1	22	45	24	25	37	G1/8"



Ausführung IK
version IK



Ausführung AK
version AK

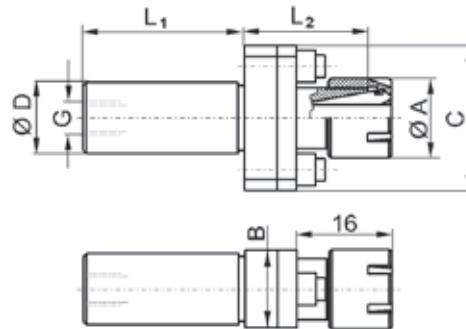

* ohne Kühlmittelanschluss - without inner coolant

STAR Maschinen-Typ / machine type:

SR10J (Pos T22+ T24); SB12 / 20R; SB16 / 20;
SR20J / JN; SR32J / JN; SR20 R / II / III; SV20R; SW12RII;
ECAS12/20; SR20RIV (Pos T21 - T24 verbaut / overlaps T25 - T28)



ER11M = M13 x 0,75



UM/ER11 = M14 x 0,75

Auch mit Standardmutter M14 x 0,75 erhältlich - Art.Nr. PHU...

Also available with standard nut M14 x 0,75 - Art. No. PHU...

Pendelhalter ER16 mit Kühlmittelanschluss

- 1 mm Pendelweg in alle Richtungen
- Sehr schmal gebaut
- Exakt paralleles Pendeln
- Selbstzentrierend
- Kein Abkippen möglich
- Incl. Standardmutter ER16M

Reamer Holders ER16 with Inner Coolant

- 1 mm float in all directions
- Compact dimensions
- Self-centreing
- Non tilting possible
- Incl. standard nut ER16M

Bestell-Nr. order-no.	D	C	B	L ₁	L ₂	G
PH161032	10	45	24	32	32	*
PH161040	10	45	24	40	32	*
PH161232	12	45	24	32	38	*
PH161240	12	45	24	40	38	*
PH161445IK	14	45	24	45	32	G1/8"
PH161650IK	16	45	24	50	32	G1/8"
PH161680IK	16	45	24	80	38	G1/8"
PH161950IK	3/4"	45	24	50	38	G1/8"
PH161970IK	3/4"	45	24	70	32	G1/8"
PH1619120IK	3/4"	45	24	120	32	G1/8"
PH162050IK	20	45	24	50	38	G1/8"
PH162070IK	20	45	24	70	32	G1/8"
PH162250IK	22	45	24	50	32	G1/8"
PH162270IK	22	45	24	70	38	G1/8"
PH1622120IK	22	45	24	120	32	G1/8"
PH162550IK	25	45	24	50	32	G1/8"
PH162570IK	25	45	24	70	38	G1/8"
PH162650IK	1"	45	24	50	32	G1/8"
PH162670IK	1"	45	24	70	32	G1/8"
PH162870IKWVD	28	45	24	70	38	G1/8"
PH161032AK1	10	45	24	32	40	G1/8"
PH161232AK1	12	45	24	32	46	G1/8"
PH161650AK1	16	45	24	50	46	G1/8"
PH162050AK1	20	45	24	50	37	G1/8"
PH162070AK1	20	45	24	70	37	G1/8"
PH162250AK1	22	45	24	50	37	G1/8"
PH162550AK1	25	45	24	50	48	G1/8"
PH162570AK1	25	45	24	70	42	G1/8"
PH1625140AK1	25	45	24	140	44	G1/8"
PH1622SRRAK1	22	45	24	25	37	G1/8"

* ohne Kühlmittelanschluss - without inner coolant



ER16M = M19 x 1



Ausführung IK
version IK



Ausführung AK
version AK

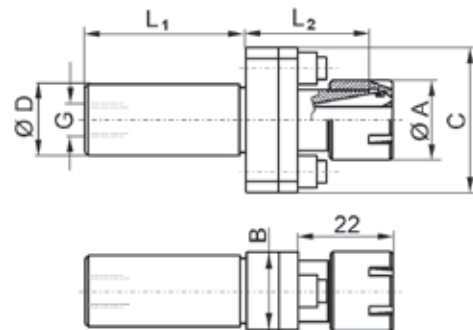

STAR Maschinen-Typ / machine type:

SR10J (Pos T22+ T24) ; SB12 / 20R ; SB16 / 20 ;
SR20J / JN ; SR32J / JN ; SR20 R / II / III ; SV20R ; SW12RII ;
ECAS12/20 ; SR20RIV (Pos T21 - T24 verbaut / overlaps T25 - T28)

Pendelhalter Typ ER11

Reamer Holders Type ER11

- 0,5 mm Pendelweg in alle Richtungen
- Mit extrem kleinen Baumaßen (z.B. für CNC Langdrehler)
- Ideal für Reibahlen von 1 mm - 7 mm (nicht einstellbar)
- Incl. Mutter ER11M / UM/ER11

- 0,5 mm float in all directions
- Very small dimensions (e.g. for CNC lathes)
- Perfect for reamers 1 mm - 7 mm (not adjustable)
- Incl. nut ER11M / UM/ER11

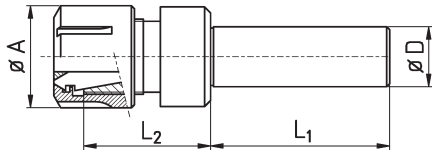

Beisp. - expl.: Mutter - nut ER11M

Mini-Mutter / mini nut			Standard-Mutter / standard nut			D	L ₁	L ₂	Bereich range	mit Bund with stop collar
Bestell-Nr. order-no.	Mutter nut	A	Bestell-Nr. order-no.	Mutter nut	A					
EPM111620BU	ER11M	16	EPU111620BU	UM/ER11	19	16	20	28	1 - 8	X
EPM111670	ER11M	16	EPU111670	UM/ER11	19	16	65	16	1 - 8	
EPM111670LBUB	ER11M	16	EPU111670LBUB	UM/ER11	19	16	63	21	1 - 8	X
EPM111670XLBU	ER11M	16	EPU111670XLBU	UM/ER11	19	16	70	26	1 - 8	X
EPM111940FLBU	ER11M	16	EPU111940FLBU	UM/ER11	19	3/4"	40	28	1 - 8	X
EPM111950FL	ER11M	16	EPU111950FL	UM/ER11	19	3/4"	50	16	1 - 8	
EPM111970FL	ER11M	16	EPU111970FL	UM/ER11	19	3/4"	70	16	1 - 8	
EPM1119120FL	ER11M	16	EPU1119120FL	UM/ER11	19	3/4"	120	16	1 - 8	
EPM1119120FLXLBU	ER11M	16	EPU1119120FLXLBU	UM/ER11	19	3/4"	120	28	1 - 8	X
EPM112070FL	ER11M	16	EPU112070FL	UM/ER11	19	20	70	16	1 - 8	
EPM1120120FLBU	ER11M	16	EPU1120120FLBU	UM/ER11	19	20	114	28	1 - 8	X
EPM112250FL	ER11M	16	EPU112250FL	UM/ER11	19	22	50	16	1 - 8	
EPM112270FL	ER11M	16	EPU112270FL	UM/ER11	19	22	70	16	1 - 8	
EPM112538FLBU	ER11M	16	EPU112538FLBU	UM/ER11	19	25	38	16	1 - 8	X
EPM112538WD	ER11M	16	EPU112538WD	UM/ER11	19	25	38	16	1 - 8	
EPM112550WD	ER11M	16	EPU112550WD	UM/ER11	19	25	50	16	1 - 8	
EPM112580WD	ER11M	16	EPU112580WD	UM/ER11	19	25	80	16	1 - 8	
EPM1125115BU	ER11M	16	EPU1125115BU	UM/ER11	19	25	115	31	1 - 8	X
EPM1125115FLBU	ER11M	16	EPU1125115FLBU	UM/ER11	19	25	115	31	1 - 8	X
EPM112680WD	ER11M	16	EPU112680WD	UM/ER11	19	1"	80	16	1 - 8	
EPM1122SR #	ER11M	16	EPM1122SR #	UM/ER11	19	22	25	27	1 - 8	X
EPM1122SRR ##	ER11M	16	EPM1122SRR ##	UM/ER11	19	22	25	27	1 - 8	X

Für STAR Maschinen-Typ / machine type:
SR32 ; SR32J
SR10J (Pos T22+ T24) ; SB12 / 20R ; SB16 / 20 ; SR20J / JN ; SR32J / JN ; SR20 R / II / III ; SV20R ; SW12RII ; ECAS12/20; SR20RIV (Pos T21 - T24 verbaut / overlaps T25 - T28)



ER11M = M13 x 0,75



UM/ER11 = M14 x 0,75

Schlüssel - spanner: E11M / GS17

Reibahlen bevorzugt in kurzer Ausführung (Automatenausführung) wählen - use reamers in short dimensions

BU = Halter mit Bund - BU = holders with flange

Pendelhalter Typ ER16

Reamer Holders Type ER16

- 0,5 mm Pendelweg in alle Richtungen
- Mit extrem kleinen Baumaßen (z.B. für CNC Langdreher)
- Ideal für Reibahlen von 1 mm - 7 mm (nicht einstellbar)
- Incl. Mutter ER16M / UM/ER16

- 0,5 mm float in all directions
- Very small dimensions (e.g. for CNC lathes)
- Perfect for reamers 1 mm - 7 mm (not adjustable)
- Incl. nut ER16M / UM/ER16

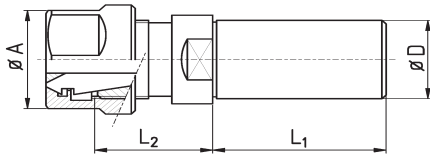

Beisp. - expl.: Mutter - nut UM/ER16

Mini-Mutter / mini nut			Standard-Mutter / standard nut			D	L ₁	L ₂	Bereich range	mit Bund with stop collar
Bestell-Nr. order-no.	Mutter nut	A	Bestell-Nr. order-no.	Mutter nut	A					
EPM161620BU	ER16M	22	EPU161620BU	UM/ER16	28	16	20	38	1 - 10	X
EPM161670	ER16M	22	EPU161670	UM/ER16	28	16	70	26	1 - 10	
EPM161670LBU	ER16M	22	EPU161670LBU	UM/ER16	28	16	60	36	1 - 10	X
EPM161670XLBU	ER16M	22	EPU161670XLBU	UM/ER16	28	16	70	36	1 - 10	X
EPM161940FLBU	ER16M	22	EPU161940FLBU	UM/ER16	28	3/4"	40	38	1 - 10	X
EPM161950FL	ER16M	22	EPU161950FL	UM/ER16	28	3/4"	50	26	1 - 10	
EPM161970FL	ER16M	22	EPU161970FL	UM/ER16	28	3/4"	70	26	1 - 10	
EPM1619120FL	ER16M	22	EPU1619120FL	UM/ER16	28	3/4"	120	26	1 - 10	
EPM1619120FLXLBU	ER16M	22	EPU1619120FLXLBU	UM/ER16	28	3/4"	120	38	1 - 10	X
EPM162070FL	ER16M	22	EPU162070FLBU	UM/ER16	28	20	70	38	1 - 10	
EPM1620120FLBU	ER16M	22	EPU1620120FLBU	UM/ER16	28	20	114	38	1 - 10	X
EPM162250FL	ER16M	22	EPU162250FL	UM/ER16	28	22	50	26	1 - 10	
EPM162270FL	ER16M	22	EPU162270FL	UM/ER16	28	22	70	26	1 - 10	
EPM162538FLBU	ER16M	22	EPU162538FLBU	UM/ER16	28	25	38	26	1 - 10	X
EPM162538WD	ER16M	22	EPM162538WD	UM/ER16	28	25	38	26	1 - 10	
EPM162550WD	ER16M	22	EPU162550WD	UM/ER16	28	25	50	26	1 - 10	
EPM162580WD	ER16M	22	EPU162580WD	UM/ER16	28	25	80	26	1 - 10	
EPM1625115BU	ER16M	22	EPU1625115BU	UM/ER16	28	25	115	41	1 - 10	X
EPM1625115FLBU	ER16M	22	EPU1625115FLBU	UM/ER16	28	25	115	41	1 - 10	X
EPM162680WD	ER16M	22	EPU162680WD	UM/ER16	28	1"	80	26	1 - 10	
EPM1622SR #	ER16M	22	EPU1622SR #	UM/ER16	28	22	25	37	1 - 10	X
EPM1622SRR ##	ER16M	22	EPU1622SRR ##	UM/ER16	28	22	25	37	1 - 10	X

Für STAR Maschinen-Typ / machine type:

SR32 ; SR32J

SR10J (Pos T22+ T24) ; SB12 / 20R ; SB16 / 20 ;
SR20J / JN ; SR32J / JN ; SR20 R / II / III ; SV20R ; SW12RII ;
ECAS12/20; SR20RIV (Pos T21 - T24 verbaut / overlaps T25 - T28)



ER16M = M19 x 1



UM/ER16 = M22 x 1,5

Schlüssel - spanner: E16M / GS25

Reibahlen bevorzugt in kurzer Ausführung (Automatenausführung) wählen - use reamers in short dimensions

BU = Halter mit Bund - BU = holders with flange

Pendelhalter Typ ER25

- 0,5 mm Pendelweg in alle Richtungen
- Kugelgelagert
- Pendelkraft mit Einstellschlüssel EPM6 verstellbar
- Incl. Standardmutter UM/ER25

Reamer Holders Type ER25

- 0,5 mm float in all directions
- Ball bearing guided
- Floating pressure adjustable with EPM6 spanner
- Incl. standard nut UM/ER25

Bestell-Nr. order-no.	D	L ₁	L ₂	Bereich range	mit Bund with stop collar
EPU25V20	20	40	62	3 - 16	X
EPU251640BU	16	40	52	3 - 16	X
EPU251945BU	3/4"	45	52	3 - 16	X
EPU252050FLBU	20	50	52	3 - 16	X
EPU252550WDBU	25	50	52	3 - 16	X
EPU2525120WDBU	25	120	52	3 - 16	X
EPU252650BU	1"	50	52	3 - 16	X
EPU252650WDBU	1"	50	52	3 - 16	X
EPU253265WDBU	32	65	52	3 - 16	X

Schlüssel - spanner: E25

BU = Halter mit Bund - BU = holders with flange

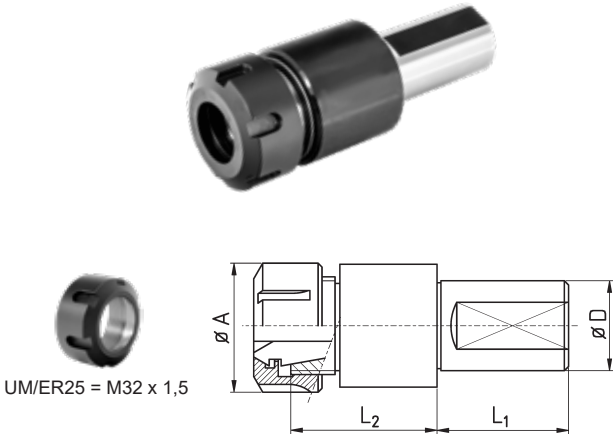

Pendelhalter Schaft mit Trapezgewinde

Reamer Holders Shank with Trapezoid Thread

Bestell-Nr. order-no.	L ₁	L ₂	D	mit Bund with stop collar
V155.T20WD	74	41	Tr20x2,0	X



UX/ER20 = M25 x 1,5



Einstellschlüssel Adjusting Spanner	Bestell-Nr. order-no.
	EPM6

Pendelhalter, einstellbar mit Zangenspannung

Adjustable Reamer Holders with Collet Clamping

- Schlanke Bauform, parallel kugelgelagert, präzise Führung
- Exaktes Parallelpendeln (Freipendeln wie z.B. Seite 54 nicht möglich)
- Zum Ausgleich von Fluchtungsfehlern beim Einsatz auf CNC-Werkzeugmaschinen
- Federkraft (Zentrierkraft) verstellbar
- Incl. Standardmutter

- Slim dimensions, accurate parallel floating
- Ball bearing guided
- No axial float possible
- Spring pressure adjustable
- Incl. standard nut

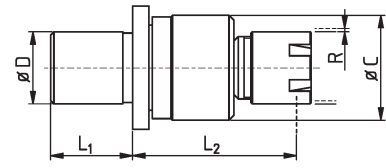
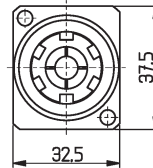
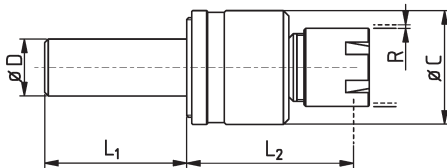

Beisp. - expl.: V155.622SW

Bestell-Nr. order-no.	Zange collet	Mutter nut	D	C	L ₁	L ₂	R
V155.516	ER11	UM/ER11	16	32	46	40	1
V155.516L	ER11	UM/ER11	16	32	60	40	1
V155.519	ER11	UM/ER11	3/4"	32	46	40	1
V155.519L	ER11	UM/ER11	3/4"	32	60	40	1
V155.520	ER11	UM/ER11	20	32	46	40	1
V155.522	ER11	UM/ER11	22	32	46	40	1
V155.522SW #	ER11	UM/ER11	22	32	25	40	2
V155.522L	ER11	UM/ER11	22	32	70	40	1
V155.525	ER11	UM/ER11	25	32	46	40	1
V155.526	ER11	UM/ER11	1"	32	46	40	1
V155.616	ER16	ER16M	16	32	46	44	1
V155.616L	ER16	ER16M	16	32	60	44	1
V155.619	ER16	ER16M	3/4"	32	46	44	1
V155.619L	ER16	ER16M	3/4"	32	70	44	1
V155.620	ER16	ER16M	20	32	46	44	1
V155.622	ER16	ER16M	22	32	46	46	1
V155.622SW #	ER16	ER16M	22	32	25	44	2
V155.625	ER16	ER16M	25	32	46	44	1
V155.626	ER16	ER16M	1"	32	46	44	1

auch mit IK lieferbar - also available with inner coolant

Für STAR Maschinen-Typ / machine type:

SW20 ; SR20RIV ; SB12/20R ; SR38 ; SV20R ; SW12RII



UM/ER11 = M14 x 0,75



ER16M = M19 x 1

Pendelhalter, einstellbar mit Zangenspannung

Adjustable Reamer Holders with Collet Clamping

- Einsatz: Freipendelnd und parallelpendelnd s. techn. Informationen S. 47
- Kann auch zum Ausgleich von Fluchtungsfehlern für starres Gewindebohren auf CNC-Werkzeugmaschinen eingesetzt werden
- Die Zentrierkraft (abhängig von der Größe der Reibahle) kann über Schraube 1 eingestellt werden
- Freipendeln über Mutter 2 einstellbar
- Incl. Standardmutter

- Axial and parallel floating
- See technical information page 47
- Screw (1) adjusts spring pressure, giving parallel float adjustment
- Nut (2) adjusts axial float
- Incl. standard nut

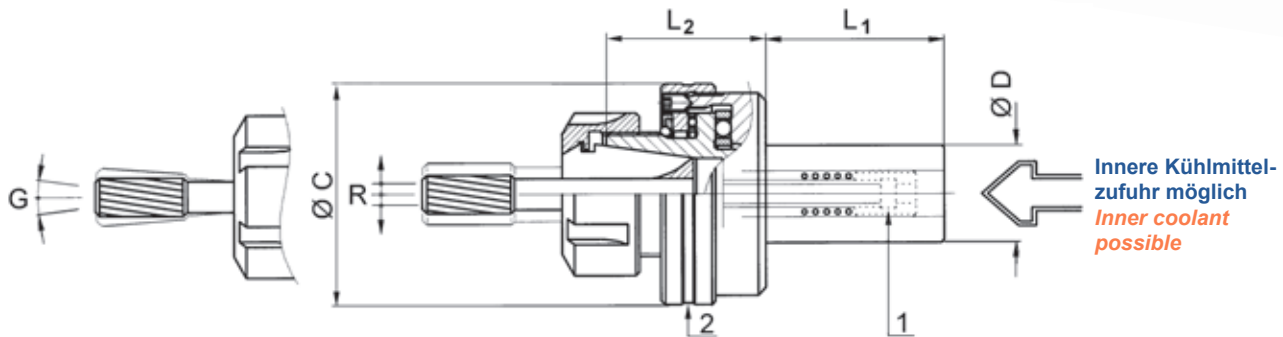

Bestell-Nr. order-no.	Zange collet	Mutter nut	D	C	L ₁	L ₂	R
V155.715 *	ER11	ER11A	5/8"	42	46	35	1
V155.716 *	ER11	ER11A	16	42	46	35	1
V155.719 *	ER11	ER11A	3/4"	42	46	35	1
V155.720 *	ER11	ER11A	20	42	46	35	1
V155.722 *	ER11	ER11A	22	42	46	34	1
V155.725 *	ER11	ER11A	25	42	46	34	1
V155.726 *	ER11	ER11A	1"	42	46	34	1
V155.015	ER16	UM/ER16	5/8"	42	46	33	1
V155.016	ER16	UM/ER16	16	42	46	33	1
V155.019	ER16	UM/ER16	3/4"	42	46	33	1
V155.020	ER16	UM/ER16	20	42	46	33	1
V155.022	ER16	UM/ER16	22	42	46	33	1
V155.025	ER16	UM/ER16	25	42	46	33	1
V155.026	ER16	UM/ER16	1"	42	46	33	1
V155.116	ER20	UM/ER20	16	50	46	39	1
V155.119	ER20	UM/ER20	3/4"	50	46	39	1
V155.120	ER20	UM/ER20	20	50	46	39	1
V155.125	ER20	UM/ER20	25	50	46	39	1
V155.126	ER20	UM/ER20	1"	50	46	39	1

Bestell-Nr. order-no.	Zange collet	Mutter nut	D	C	L ₁	L ₂	R
V155.216	ER25	UM/ER25	16	57	46	41	1
V155.219	ER25	UM/ER25	3/4"	57	46	41	1
V155.220	ER25	UM/ER25	20	57	46	41	1
V155.222	ER25	UM/ER25	22	57	46	41	1
V155.225	ER25	UM/ER25	25	57	46	41	1
V155.226	ER25	UM/ER25	1"	57	46	41	1
V155.232	ER25	UM/ER25	32	57	46	41	1
V155.325	ER32	UM/ER32	25	69	50	45	1,5
V155.326	ER32	UM/ER32	1"	69	50	45	1,5
V155.330	ER32	UM/ER32	30	69	50	45	1,5
V155.331	ER32	UM/ER32	1 1/4"	69	50	45	1,5
V155.332	ER32	UM/ER32	32	69	50	45	1,5
V155.425	ER40	UM/ER40	25	79	50	49	1,5
V155.426	ER40	UM/ER40	1"	79	50	49	1,5
V155.430	ER40	UM/ER40	30	79	50	49	1,5
V155.431	ER40	UM/ER40	1 1/4"	79	50	49	1,5
V155.432	ER40	UM/ER40	32	79	50	49	1,5

* Halter mit Außengewinde-Mutter ER11A

* Holder with external thread nuts ER11A



ER11AEX = M18 x 1



UM/ER16 = M22 x 1,5



UM/ER20 = M25 x 1,5



UM/ER25 = M32 x 1,5



UM/ER32 = M40 x 1,5



UM/ER40 = M50 x 1,5

Einstellbare VDI-Pendelhalter mit Zange

Adjustable VDI-Reamer Holders with Collet

- Einsatz: Freipendelnd (G) und parallelpendelnd (R) siehe techn. Informationen S. 47
- Kann auch zum Ausgleich von Fluchtungsfehlern für starres Gewindebohren auf CNC-Werkzeugmaschinen eingesetzt werden
- Die Zentrierkraft (abhängig von der Größe der Reibahle) kann über Schraube 2 eingestellt werden
- Freipendeln (G) über Mutter 3 einstellbar

- Axial (G) and parallel (R) floating
- See technical information page 47
- Screw (2) adjusts spring pressure, giving parallel float adjustment
- Nut (3) adjusts axial float (G)

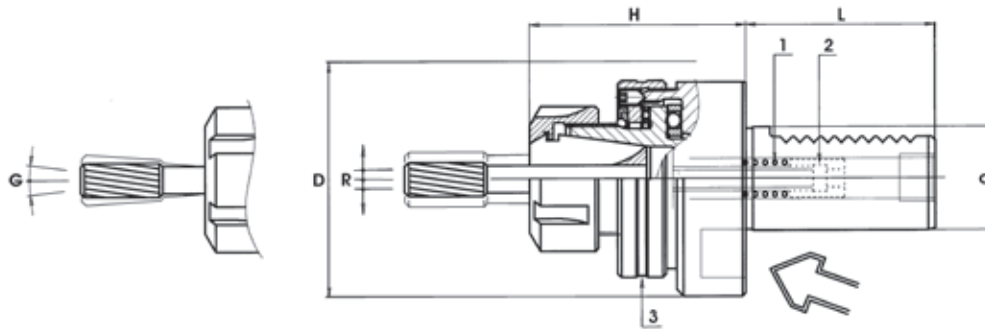

UM/ER25 = M32 x 1,5



UM/ER32 = M40 x 1,5

Bestell-Nr. order-no.	D	C	L ₁	L ₂	R	Zange collet
V155.9 K3.20.25	20	57	40	56	1	ER25
V155.9 K3.30.25	30	68	55	59	1	ER25
V155.9 K3.30.32	30	68	55	64	1,5	ER32
V155.9 K3.40.32	40	83	63	63	1,5	ER32

Incl. Mutter

supplied with nut

Pendelhalter, einstellbar mit Morsekonus

Adjustable Reamer Holders with Morse Cone

- Einsatz: Freipendelnd und parallelpendelnd s. techn. Informationen S.47
- Kann auch zum Ausgleich von Fluchtungsfehlern für starres Gewindebohren auf CNC-Werkzeugmaschinen eingesetzt werden.
- Incl. Standardmutter

- *Axial and parallel floating*
- *See technical information page 47*
- *Incl. standard nut*

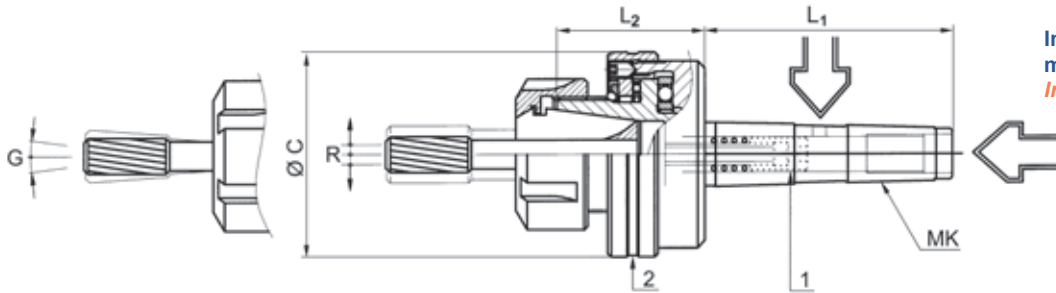

Innere Kühlmittelzufuhr möglich
Inner coolant possible

Bestell-Nr. order-no.	Zange collet	Mutter nut	MK	C	L ₁	L ₂	R
V155.702	ER11	UM/ER11	MK2	42	69	35	1
V155.703	ER11	UM/ER11	MK3	42	86	35	1
V155.002	ER16	UM/ER16	MK2	42	69	34	1
V155.003	ER16	UM/ER16	MK3	42	86	34	1
V155.102	ER20	UM/ER20	MK2	50	69	39	1
V155.103	ER20	UM/ER20	MK3	50	86	39	1
V155.202	ER25	UM/ER25	MK2	57	69	41	1
V155.203	ER25	UM/ER25	MK3	57	86	41	1
V155.303	ER32	UM/ER32	MK3	69	86	45	1.5
V155.304	ER32	UM/ER32	MK4	69	109	45	1.5
V155.404	ER40	UM/ER40	MK4	79	109	49	1.5



UM/ER11 = M14 x 0,75



UM/ER16 = M22 x 1,5



UM/ER20 = M25 x 1,5



UM/ER25 = M32 x 1,5



UM/ER32 = M40 x 1,5



UM/ER40 = M50 x 1,5

Austreiberlappen für MK-Futter s. Seite 30
Ejector Drifts for MT-Holders see page 30